

User Guide

ICM SMT 360™ & RES SMT 360™ Multi-GNSS Timing Modules

For use with:

ICM SMT 360™ multi-GNSS Timing Module (P/N 96975-xx)

RES SMT 360™ multi-GNSS Timing Module (P/N 97975-xx & 102013-xx)

ICM SMT 360™ multi-GNSS Timing Module on Carrier Board (P/N 67974-xx)

RES SMT 360™ multi-GNSS Timing Module on Carrier Board (P/N 97779-xx)

ICM SMT 360™ multi-GNSS Starter Kit (P/N 94471-05)

RES SMT 360™ multi-GNSS Starter Kit (P/N 96960-05)

Firmware Version 1.05 and above

Version G
April 2018
Part Number 94472-00



Legal Notices

Corporate Office

Trimble, Inc.
Component Technologies
935 Stewart Drive
Sunnyvale, CA 94085
U.S.A.
+1-800-767-4822 (toll-free in the USA)
www.trimble.com/timing
Email: tsgsupport@trimble.com

Copyright and Trademarks

© 2017, Trimble, Inc..

Trimble and the Globe & Triangle logo are trademarks of Trimble, Inc., registered in the United States and in other countries. Bullet, ICM SMT 360™ and RES SMT 360™ are trademarks of Trimble, Inc..

Microsoft, Windows, and Windows Vista are either registered trademarks or trademarks of Microsoft Corporation in the United States and/or other countries.

All other trademarks are the property of their respective owners.

Release Notice

This is the April 2017 release (Revision F) of the *ICM SMT 360™ and RES SMT 360™ multi-GNSS Timing Module User Guide*, part number 94472-00

LIMITED WARRANTY TERMS AND CONDITIONS

Product Limited Warranty

Subject to the following terms and conditions, Trimble, Inc. ("Trimble") warrants that for a period of one (1) year from date of purchase this Trimble product (the "Product") will substantially conform to Trimble's publicly available specifications for the Product and that the hardware and any storage media components of the Product will be substantially free from defects in materials and workmanship.

Product Software

Product software, whether built into hardware circuitry as firmware, provided as a standalone computer software product, embedded in flash memory, or stored on magnetic or other media, is licensed solely for use with or as an integral part of the Product and is not sold. If accompanied by a separate end user license agreement ("EULA"), use of any such software will be subject to the terms of such end user license agreement (including any differing limited warranty terms, exclusions, and limitations), which shall control over the terms and conditions set forth in this limited warranty.

Software Updates

During the limited warranty period you will be entitled to receive such updates to the Product software that Trimble releases and makes commercially available and for which it does not charge separately, subject to the procedures for delivery to purchasers of Trimble products generally. If you have purchased the Product from an authorized Trimble dealer rather than from Trimble directly, Trimble may, at its option, forward the software Fix to the Trimble dealer for final distribution to you. Minor Updates, Major Upgrades, new products, or substantially new software releases, as identified by Trimble, are expressly excluded from this update process and limited warranty. Receipt of software updates or other enhancements shall not serve to extend the limited warranty period.

For purposes of this warranty the following definitions shall apply: (1) "Fix(es)" means an error correction or other update created to fix a previous software version that does not substantially conform to its Trimble specifications; (2) "Minor Update" occurs when enhancements are made to current features in a software program; and (3) "Major Upgrade" occurs when significant new features are added to software, or when a new product containing new features replaces the further development of a current product line. Trimble reserves the right to determine, in its sole discretion, what constitutes a Fix, Minor Update, or Major Upgrade.

Warranty Remedies

If the Trimble Product fails during the warranty period for reasons covered by this limited warranty and you notify Trimble of such failure during the warranty period, Trimble will repair OR replace the nonconforming Product with new, equivalent to new, or reconditioned parts or Product, OR refund the Product purchase price paid by you, at Trimble's option, upon your return of the Product in accordance with Trimble's product return procedures then in effect.

How to Obtain Warranty Service

To obtain warranty service for the Product, please contact your local Trimble representative or distributor. Alternatively, you may contact Trimble to request warranty service by sending an email to tsgsupport@trimble.com, including the following information:

- your name, address, and telephone numbers
- proof of purchase
- a copy of this Trimble warranty
- a description of the nonconforming Product including the model number
- an explanation of the problem

The customer service representative may need additional information from you depending on the nature of the problem.

Warranty Exclusions and Disclaimer

This Product limited warranty shall only apply in the event and to the extent that (a) the Product is properly and correctly installed, configured, interfaced, maintained, stored, and operated in accordance with Trimble's applicable operator's manual and specifications, and; (b) the Product is not modified or misused. This Product limited warranty shall not apply to, and Trimble shall not be responsible for, defects or performance problems resulting from (i) the combination or utilization of the Product with hardware or software products, information, data, systems, interfaces, or devices not made, supplied, or specified by Trimble; (ii) the operation of the Product under any specification other than, or in addition to, Trimble's standard specifications for its products; (iii) the unauthorized installation, modification, or use of the Product; (iv) damage caused by: accident, lightning or other electrical discharge, fresh or salt water immersion or spray (outside of Product specifications); or exposure to environmental conditions for which the Product is not intended; (v) normal wear and tear on consumable parts (e.g., batteries); or (vi) cosmetic damage. Trimble does not warrant or guarantee the results obtained through the use of the Product, or that software components will operate error free.

NOTICE REGARDING PRODUCTS EQUIPPED WITH TECHNOLOGY CAPABLE OF TRACKING SATELLITE SIGNALS FROM SATELLITE BASED AUGMENTATION SYSTEMS (SBAS) (WAAS/EGNOS, AND MSAS), OMNISTAR, GPS, MODERNIZED GPS OR GLONASS SATELLITES, OR FROM IALA BEACON SOURCES: TRIMBLE IS NOT RESPONSIBLE FOR THE OPERATION OR FAILURE OF OPERATION OF ANY SATELLITE BASED POSITIONING SYSTEM OR THE AVAILABILITY OF ANY SATELLITE BASED POSITIONING SIGNALS.

THE FOREGOING LIMITED WARRANTY TERMS STATE TRIMBLE'S ENTIRE LIABILITY, AND YOUR EXCLUSIVE REMEDIES, RELATING TO THE TRIMBLE PRODUCT. EXCEPT AS OTHERWISE EXPRESSLY PROVIDED HEREIN, THE PRODUCT, AND ACCOMPANYING DOCUMENTATION AND MATERIALS ARE PROVIDED "AS-IS" AND WITHOUT EXPRESS OR IMPLIED WARRANTY OF ANY KIND, BY EITHER TRIMBLE OR ANYONE WHO HAS BEEN INVOLVED IN ITS CREATION, PRODUCTION, INSTALLATION, OR DISTRIBUTION, INCLUDING, BUT NOT LIMITED TO, THE IMPLIED WARRANTIES OF MERCHANTABILITY AND FITNESS FOR A PARTICULAR PURPOSE, TITLE, AND NONINFRINGEMENT. THE STATED EXPRESS WARRANTIES ARE IN LIEU OF ALL OBLIGATIONS OR LIABILITIES ON THE PART OF TRIMBLE ARISING OUT OF, OR IN CONNECTION WITH, ANY PRODUCT. BECAUSE SOME STATES AND JURISDICTIONS DO NOT ALLOW LIMITATIONS ON DURATION OR THE EXCLUSION OF AN IMPLIED WARRANTY, THE ABOVE LIMITATION MAY NOT APPLY OR FULLY APPLY TO YOU.

Limitation of Liability

TRIMBLE'S ENTIRE LIABILITY UNDER ANY PROVISION HEREIN SHALL BE LIMITED TO THE AMOUNT PAID BY YOU FOR THE PRODUCT. TO THE MAXIMUM EXTENT PERMITTED BY APPLICABLE LAW, IN NO EVENT SHALL TRIMBLE OR ITS SUPPLIERS BE LIABLE FOR ANY INDIRECT, SPECIAL, INCIDENTAL, OR CONSEQUENTIAL DAMAGE WHATSOEVER UNDER ANY CIRCUMSTANCE OR LEGAL THEORY RELATING IN ANYWAY TO THE PRODUCTS, SOFTWARE AND ACCOMPANYING DOCUMENTATION AND MATERIALS, (INCLUDING, WITHOUT LIMITATION, DAMAGES FOR LOSS OF BUSINESS PROFITS, BUSINESS INTERRUPTION, LOSS OF DATA, OR ANY OTHER PECUNIARY LOSS), REGARDLESS OF WHETHER TRIMBLE HAS BEEN ADVISED OF THE POSSIBILITY OF ANY SUCH LOSS AND REGARDLESS OF THE COURSE OF DEALING WHICH DEVELOPS OR HAS DEVELOPED BETWEEN YOU AND TRIMBLE. BECAUSE SOME STATES AND JURISDICTIONS DO NOT ALLOW THE EXCLUSION OR LIMITATION OF LIABILITY FOR CONSEQUENTIAL OR INCIDENTAL DAMAGES, THE ABOVE LIMITATION MAY NOT APPLY OR FULLY APPLY TO YOU.

PLEASE NOTE: THE ABOVE TRIMBLE LIMITED WARRANTY PROVISIONS WILL NOT APPLY TO PRODUCTS PURCHASED IN THOSE JURISDICTIONS (E.G., MEMBER STATES OF THE EUROPEAN ECONOMIC AREA) IN WHICH PRODUCT WARRANTIES ARE THE RESPONSIBILITY OF THE LOCAL TRIMBLE AUTHORIZED DEALER FROM WHOM THE PRODUCTS ARE ACQUIRED. IN SUCH A CASE, PLEASE CONTACT YOUR LOCAL TRIMBLE AUTHORIZED DEALER FOR APPLICABLE WARRANTY INFORMATION.

Official Language

THE OFFICIAL LANGUAGE OF THESE TERMS AND CONDITIONS IS ENGLISH. IN THE EVENT OF A CONFLICT BETWEEN ENGLISH AND OTHER LANGUAGE VERSIONS, THE ENGLISH LANGUAGE SHALL CONTROL.

Notices

Class B Statement – Notice to Users. This equipment has been tested and found to comply with the limits for a Class B digital device, pursuant to Part 15 of the FCC rules. These limits are designed to provide reasonable protection against harmful interference in a residential installation. This equipment generates, uses, and can radiate radio frequency energy and, if not installed and used in accordance with the instructions, may cause harmful interference to radio communication. However, there is no guarantee that interference will not occur in a particular installation. If this equipment does cause harmful interference to radio or television reception, which can be determined by turning the equipment off and on, the user is encouraged to try to correct the interference by one or more of the following measures:

- Reorient or relocate the receiving antenna.
- Increase the separation between the equipment and the receiver.
- Connect the equipment into an outlet on a circuit different from that to which the receiver is connected.
- Consult the dealer or an experienced radio/TV technician for help.

Changes and modifications not expressly approved by the manufacturer or registrant of this equipment can void your authority to operate this equipment under Federal Communications Commission rules.

Canada

This digital apparatus does not exceed the Class B limits for radio noise emissions from digital apparatus as set out in the radio interference regulations of the Canadian Department of Communications, ICES-003.

Le présent appareil numérique n'émet pas de bruits radioélectriques dépassant les limites applicables aux appareils numériques de Classe B prescrites dans le règlement sur le brouillage radioélectrique édicté par le Ministère des Communications du Canada, ICES-003.

Europe

This product has been tested and found to comply with the requirements for a Class B device pursuant to European Council Directive 89/336/EEC on EMC, thereby satisfying the requirements for CE Marking and sale within the European Economic Area (EEA). These requirements are designed to provide reasonable protection against harmful interference when the equipment is operated in a residential or commercial environment.



Notice to Our European Union Customers

For product recycling instructions and more information, please go to www.trimble.com/ev.shtml.

Recycling in Europe: To recycle Trimble WEEE (Waste Electrical and Electronic Equipment, products that run on electrical power.), Call +31 497 53 24 30, and ask for the "WEEE Associate". Or, mail a request for recycling instructions to:



Trimble Europe BV
c/o Menlo Worldwide Logistics
Meerheide 45
5521 DZ Eersel, NL

Declaration of Conformity

We, Trimble, Inc.,

935 Stewart Drive
Sunnyvale, CA 94085-3913
United States
+1-408-481-8000

declare under sole responsibility that the product: ICM SMT 360™ Timing Module Starter Kit complies with Part 15B of FCC Rules.

Operation is subject to the following two conditions:
(1) this device may not cause harmful interference, and
(2) this device must accept any interference received, including interference that may cause undesired operation.

List of Abbreviations

Acronym	Definition
A-GPS	Assisted GPS
C/N₀	Carrier-to-Noise power ratio
DOP	Dilution of Precision
EGNOS	European Geostationary Navigation Overlay Service
ESD	Electrostatic Discharge
GLONASS	Globalnaya Navigatsionnaya Sputnikovaya Sistema
GND	Ground
GNSS	Global Navigation Satellite System
GPS	Global Positioning System
LNA	Low Noise Amplifier
MSL	Mean Sea Level
NMEA	National Marine Electronics Association
PCB	Printed Circuit Board
PDOP	Position Dilution of Precision
PPS	Pulse Per Second
QZSS	Quasi-Zenith Satellite System
RF	Radio Frequency
RMS	Root Mean Square
T-RAIM	Timing Receiver Autonomous Integrity Monitoring
TSIP	Trimble Standard Interface Protocol
TTFF	Time to First Fix
UTC	Universal Coordinated Time
VSWR	Voltage Standing Wave Ratio
VTS	Trimble Visual Timing Studio
WNRO	Week Number Roll-Over

Safety Information

Warnings and Cautions

An absence of specific alerts does not mean that there are no safety risks involved. Always follow the instructions that accompany a Warning or Caution. The information they provide is intended to minimize the risk of personal injury and/or damage to the equipment. In particular, observe safety instructions that are presented in the following formats:

WARNING – A Warning alerts you to a likely risk of serious injury to your person and/or damage to the equipment.

CAUTION – A Caution alerts you to a possible risk of damage to the equipment and/or loss of data.

Operation and storage

CAUTION – The ICM SMT 360™ is ready to accept TSIP (Trimble Standard Interface Protocol) or NMEA commands approximately 10 seconds after power-up. If a command is sent to the receiver within this 10 second window, the receiver may ignore the command. The ICM SMT 360™ may not respond to commands sent within the 10 second window and may discard any associated command data.

CAUTION – ICM SMT 360™ may not start-up properly if the TxD pin is actively driven or being pulled high or pulled-low during power-on! Do not actively drive or pull-high or pull-low the TxD pin in order to ensure a normal start-up after power-on.

WARNING – Operating or storing the ICM SMT 360™ outside the specified temperature range can damage it. For more information, see the product specifications on the data sheet.

Handling

CAUTION – The ICM SMT 360™ multi-GNSS timing module is packed according to ANSI/EIA-481-B and JSTD-033A. All of the handling and precaution procedures must be followed. Deviation from following handling procedures and precautions voids the warranty.

CAUTION – Operators should not touch any part of ICM SMT 360™ by hand or with contaminated gloves. Ensure that no hand lotion or regular chlorinated faucet water comes in contact with the module.

CAUTION – The open board assembly is an electrostatic-sensitive device. Appropriate care and protection against ESD, according to JEDEC standard JESD625-A (EIA 625) and IEC 61340-5-1, must be taken when handling the product.

CAUTION – Do not bake the units within the tape and reel packaging. Repeated baking processes will reduce the solderability.

CAUTION – Follow the thermal reflow guidelines from IPC-JEDEC J-STD-020C.

Routing any cable

CAUTION – Be careful not to damage the cable. Take care to avoid sharp bends or kinks in the cable, hot surfaces (for example, exhaust manifolds or stacks), rotating or reciprocating equipment, sharp or abrasive surfaces, door and window jambs, and corrosive fluids or gases.

AC adaptor safety

An international adaptor kit is provided with the ICM SMT 360™ Starter Kit.

WARNING – Using an incorrect AC adaptor can damage your product and may void your warranty. To use AC adaptors safely:

- Use only the AC adaptor intended for the ICM SMT 360™ multi-GNSS timing module. Using any other AC adaptor can damage your product and may void your warranty.
- Do not use the AC adaptor with any other product.
- Make certain that the input voltage on the adaptor matches the voltage and frequency in your location.
- Make certain that the adaptor has prongs compatible with your outlets.
- AC adaptors are designed for indoor use only. Avoid using the AC adaptor in wet outdoor areas.
- Unplug the AC adaptor from power when not in use.
- Do not short the output connector.
- There are no user-serviceable parts in this product.
- Should damage to the AC adaptor occur, replace it with a new Trimble AC adaptor.

Table of Content

Legal Notices	3
List of Abbreviations	5
Safety Information	6
Warnings and Cautions	6
Operation and storage	6
Handling.....	6
Routing any cable	7
AC adaptor safety	7
Table of Content	8
Introduction	17
Overview.....	18
Timing Features	18
Other Key features	19
Tools and Accessories.....	19
Use and Care.....	19
Technical Assistance	19
System Operation	21
GNSS Timing	22
Time References.....	22
GNSS Constellation Configuration.....	23
PPS and 10 MHz Availability	23
Start-up.....	23
Automatic operation	24
Satellite masks	24
Elevation mask.....	24
C/No mask.....	25
PDOP mask.....	25
Operating modes.....	25
Self-survey mode	26
Over-determined clock mode.....	26
Integrity Monitoring	27

Cable Delay Compensation.....	27
Timing module Performance.....	27
Acquiring the correct time	28
Holdover stability (ICM SMT 360)	29
Customizing operation	29
ICM/RES SMT 360™ Features & Specifications.....	31
Key Features	32
Res SMT 360 Timing Specification.....	33
ICM SMT 360 Timing Specification.....	33
ICM SMT 360 System Clock	33
Physical Specifications.....	33
Mechanical outline drawing.....	34
ICM SMT 360 Block diagram.....	35
ICM SMT 360 Pin Assignment.....	35
RES SMT 360 Block diagram	36
RES SMT 360 Pin Assignment	36
Pin description.....	37
Detailed pin descriptions.....	38
RFIN.....	38
OPEN / SHORT pins	38
RESET pin.....	38
VCC pin.....	39
PPS_IN pin (ICM SMT 360 only)	39
PPS pin	39
RXDA, RXDB pins	39
TXDA, TXDB pins.....	39
Reserved pins.....	40
Absolute Maximum Ratings	40
Recommended operating conditions	40
Electrical Specifications	41
Power requirements	41
Grounding	41
Serial interface.....	41

Pulse-per-second (PPS).....	41
10MHz frequency output (SYSCLK) – <i>For ICM SMT 360</i>	42
Environmental Specifications	42
Protection against Electrostatic Discharge (ESD).....	42
Surge Protection	43
EMI	43
GNSS Antenna	45
GNSS Antenna	46
Antenna requirements.....	46
Antenna OPEN/SHORT Detection	47
Antenna Placement	47
Sky-Visibility	47
Multipath-reflections.....	48
Jamming	48
Ground Plane	48
Application Circuits	49
Active antenna – no antenna status.....	50
Active antenna – antenna short protection	51
Active antenna – antenna open and short protection	52
RF Layout Considerations.....	53
General recommendations.....	54
Design considerations for RF track topologies	55
PCB considerations	56
Microstrip transmission lines.....	56
Stripline transmission lines	57
Packaging	59
Introduction.....	60
Reel.....	60
Weight	61
Tapes	61
Label	62
Shipping and Handling	63
Shipping and Handling Guidelines.....	64

Handling	64
Shipment.....	64
Storage	64
Moisture Indicator	64
Floor Life	64
Moisture precondition	65
Baking procedure	65
Soldering Guideline.....	67
Solder Pad pattern.....	68
Solder mask	68
Soldering paste.....	68
Solder reflow	69
Recommended soldering profile	69
Optical inspection.....	69
Cleaning.....	70
Orientation for reflow soldering	70
Repeated reflow soldering	70
Wave soldering.....	70
Hand soldering.....	70
Rework.....	70
Conformal coating	71
ICM/RES SMT 360™ on a Carrier Board	73
ICM SMT 360™ Carrier Board Visual Appearance	74
Physical Specifications.....	74
Mechanical specification	75
Mounting.....	75
Interface connectors	75
RF Antenna connector	75
Digital IO/Power connector	75
Mating connectors.....	75
Digital IO/Power connector pin-out	76
Power requirements.....	76
Supply voltage control	76

Power-sequencing	77
Serial interface.....	77
Pulse-per-second (PPS).....	77
10 MHz frequency output (SYSCLK) - ICM SMT 360 only	77
Antenna OPEN/SHORT Detection.....	78
Surge Protection.....	79
GNSS antenna.....	80
ICM/RES SMT 360™ Starter Kit	83
ICM/RES SMT 360™ Starter Kit Content.....	84
Universal Interface Module.....	85
Powering the UIM	86
AC/DC power converter	86
Pulse-per-second (PPS).....	86
10 MHz Frequency Output (<i>ICM SMT 360 only</i>).....	86
System requirements	87
Hardware	87
Software.....	87
Using the ICM/RES SMT 360™ Starter Kit with VTS	87
Removing the ICM/RES SMT 360™ Carrier Board from the UIM	87
Software Interface	89
Communicating with the receiver	90
Protocols	90
Serial port default settings.....	90
Software tools.....	91
Assisted GPS (A-GPS).....	93
Note that this feature applies to only the GPS constellation.....	93
Assisted GPS (applies to GPS constellation only)	94
Prerequisites for the Trimble A-GPS solution.....	94
A-GPS Operating Mode	95
A-GPS TSIP Message Flow Illustration	96
A-GPS with the Trimble Visual Timing Studio (VTS) application	97
Enabling A-GPS with TSIP	99
Trimble Standard Interface Protocol	101

Introduction.....	102
Interface scope	102
TSIP (Trimble Serial Interface Protocol) Packet Structure.....	102
Subpackets.....	103
Data Types.....	103
Configuration Parameters	104
GNSS Configuration.....	104
Packet I/O Control.....	104
Serial Port Configuration.....	104
Timing Outputs	105
Automatic Output Packets	105
Packets Output at Reset	106
Input Packets Supported	107
Output Packets Supported	108
Packet Descriptions	110
Report packet 0x13: Unparsable packet.....	110
Command packet 0x1C-01: Firmware Version	110
Report packet 0x1C-81: Firmware component version information.....	110
Command packet 0x1C-03: Hardware component version information	111
Report packet 0x1C-83: Hardware component version information	111
Command packet 0x1E: Initiate Cold, Warm, or Factory Reset.....	112
Command packet 0x1F: Request Software Version.....	112
Command Packet 0x21: Current Time Request	112
Command packet 0x24: Request GNSS satellite Selection	112
Command Packet 0x26: Health Request.....	112
Command packet 0x27: Request Signal Levels.....	112
Command packet 0x2B: Set Approximate Initial Position	112
Command packet 0x2E: Set GPS Time	113
Command packet 0x2E-00: Request GPS Time (ICM/RES→Server only).....	114
Command packet 0x30: Set UTC Date and Time for future roll over date	114
Command packet 0x31: Accurate Initial Position (XYZ Cartesian ECEF)	114
Command packet 0x32: Accurate Initial Position (Latitude, Longitude, Altitude)	115
Command packet 0x32-00: Request GPS Position (ICM/RES →Server only).....	115

Command packet 0x35: Set or Request I/O Options	116
Command packet 0x37: Request Status and Values of Last Position	117
Command packet 0x38: Request Satellite System Data	118
Command packet 0x38: Upload Satellite System Data.....	118
Command Packet 0x39: Satellite Attribute Database Command	121
Command packet 0x3A: Request Last Raw Measurement.....	122
Command packet 0x3C: Request Satellite Tracking Status	122
Command packet 0x7A: NMEA Interval and Message Mask Command	123
Report Packet 0x41: GPS Time Report.....	123
Report packet 0x42: Single-precision Position Fix	124
Report packet 0x43: Velocity Fix, XYZ ECEF	124
Report packet 0x45: Software Version Information	124
Report Packet 0x46: Health of Receiver Report	125
Report packet 0x47: Signal Level for All Satellites Tracked	126
Report packet 0x4A: Single Precision LLA position Fix	126
Report Packet 0x4B: Machine/Code ID and Additional Status Report	127
Report packet 0x4E: GPS Time Command Verification	127
Report packet 0x55: I/O Options	128
Report packet 0x56: Velocity Fix, East-North-Up (ENU).....	128
Report packet 0x57: Information about Last Computed Fix	128
Report packet 0x58: GPS System Data from Receiver	129
Report Packet 0x59: Satellite Attributes Database Report.....	129
Report packet 0x5A: Raw Data Measurement Data	131
Report packet 0x5D: GNSS Satellite Tracking Status	131
Report packet 0x5F-01-0B: Reset Error Codes.....	132
Report packet 0x6C: Satellite Selection List.....	133
Report Packet 0x7B: Set NMEA Message Output.....	133
Report packet 0x83: Double Precision XYZ	133
Report packet 0x84: Double Precision LLA Position (Fix and Bias Information).....	134
Command packet 0xBB: Set Receiver Configuration	134
Command packet 0xBC: Set Port Configuration	136
Command packet 0x8E-02 Request UTC Information	137
Command packet 0x8E-26: Request Configuration to Flash ROM	137

Command packet 0x8E-41: Request Manufacturing Parameters	137
Command packet 0x8E-42: Stored Production Parameters	137
Command packet 0x8E-4A: Set PPS Characteristics	137
Command packet 0x8E-4B: Set external PPS offset (<i>ICM SMT 360 only</i>)	138
Command packet 0x8E-4E : Set PPS Output Option.....	138
Command packet 0x8E-A2: UTC/GPS Timing	139
Command packet 0x8E-A3: Issue Oscillator Disciplining Command (<i>ICM SMT 360 only</i>)	139
Command packet 0x8E-A5: Packet Broadcast Mask	140
Command Packet 0x8E-A6: Self-Survey Command	140
Command Packet 0x8E-A7: Set desired reference (<i>ICM SMT 360 only</i>).....	141
Command packet 0x8E-A8: Set or Request Disciplining Parameters (<i>ICM SMT 360 only</i>).....	141
Command Packet 0x8E-A9: Self-Survey Parameters	143
Command packet 0x8E-AB: Request Primary Timing Packet	144
Command packet 0x8E-AC: Request Supplemental Timing Packet.....	144
Report packet 0x8F-02: UTC Information	145
Report packet 0x8F-41: Stored Manufacturing Operating Parameters	145
Report packet 0x8F-42: Stored Production Parameters.....	147
Report packet 0x8F-4A: Set PPS Characteristics.....	147
Report packet 0x8F-4B: Set external PPS offset (<i>ICM SMT 360 only</i>).....	147
Report packet 0x8F-4E: PPS Output.....	147
Report packet 0x8F-A0: DAC Value (<i>ICM SMT 360 only</i>)	147
Report packet 0x8F-A2: UTC/GPS Timing	148
Report packet 0x8F-A3: Oscillator Disciplining Command (<i>ICM SMT 360 only</i>).....	148
Report packet 0x8F-A5: Packet Broadcast Mask	148
Report Packet 0x8F-A6: Self-Survey Command.....	149
Report Packet 0x8F-A7: Set desired reference (<i>ICM SMT 360 only</i>)	149
Report packet 0x8F-A8: Oscillator Disciplining Parameters (<i>ICM SMT 360 only</i>).....	149
Report Packet 0x8F-A9: Self-Survey Parameters.....	149
Report packet 0x8F-AB: Primary Timing Packet	149
Report packet 0x8F-AC: Supplemental Timing Packet.....	151
NMEA 0183 Protocol.....	157
Introduction.....	158
NMEA 0183 communication interface	158

NMEA 0183 message structure	159
Field definitions	159
NMEA 0183 message options.....	161
ICM/RES SMT 360™ multi-GNSS timing module proprietary NMEA messages.....	161
NMEA 0183 message formats	163
GGA-GPS Fix Data.....	163
GLL - Geographic Position - Latitude/Longitude	163
GSA - GPS DOP and Active Satellites.....	164
GSV - GPS Satellites in View	164
RMC - Recommended Minimum Specific GPS/Transit Data.....	165
VTG - Track Made Good and Ground Speed.....	165
ZDA - Time & Date.....	166
AH - Almanac Health	166
AL - Almanac Page.....	167
AS - Almanac Status	168
BA - Antenna Status	169
CR - Configure Receiver	169
EM - Enter Monitor Mode.....	170
EP - Ephemeris	170
IO - Ionosphere	172
KG - Set Initial Position.....	173
NM - Automatic Message Output	173
PS - PPS Configuration	174
PT - Serial Port Configuration.....	175
RT - Reset	176
TF - Receiver Status and Position Fix	176
UT - UTC	177
VR - Version.....	178
ZD – Extended Time and Date.....	179
Exception behavior	180
Interruption of GNSS signal.....	180
Contact Information	182

Introduction

In this chapter:

Overview

Timing features

Tools and Accessories

Use and care

Technical assistance

Welcome to the Trimble ICM SMT 360™ and RES SMT 360™ multi-GNSS Timing Module User Guide. The user guide describes how to integrate and operate the Trimble® ICM & RES SMT 360™ timing module.

The Trimble ICM SMT 360™ timing module is a full featured, high-performance multi-GNSS receiver with precise PPS and 10 MHz output. The receiver is designed to operate on the GPS L1, Galileo, GLONASS G1 and BeiDou B1 frequencies, providing standard position service (SPS) using Coarse Acquisition (C/A) code. The RES SMT 360™ timing module supports all features of ICM SMT 360™ except 10MHz frequency output & holdover.

The Trimble ICM & RES SMT 360™ products are designed for 3.3 V prime power.

For more information on Trimble timing and synchronization products go to <http://www.trimble.com/timing/>

For more information on GNSS, go to: http://www.trimble.com/gps_tutorial/

Overview

The ICM/RES SMT 360™ are complete all-in-view, parallel tracking GNSS receiver designed to operate with the GPS, Galileo, GLONASS, BeiDou and QZSS L1 frequencies 1551MHz to 1614MHz, standard position service, and Coarse Acquisition code. When connected to an external GNSS antenna, the receiver contains all the circuitry necessary to automatically acquire GNSS satellite signals, track up to 32 GNSS satellites, and compute location, speed, heading, and time. It provides an accurate one pulse-per-second (PPS) and stable 10 MHz frequency output to synchronize broadband wireless, cellular base stations such as 4G LTE eNodeB's aggregation and pre-aggregation routers, Time Difference of Arrival (TDOA) applications, and many other Supervisory Control and Data Acquisition (SCADA) applications.

The ICM/RES SMT 360™ can also be used as a reference source for use in laboratories, automation, R&D facilities. In calibration laboratories, the ICM/RES SMT 360™ is fully traceable to national standards through the atomic clocks carried on GNSS satellites — this eliminates the calibration cycle required with more traditional sources.

The ICM SMT 360™ and RES SMT 360™ automatically initiate a self-survey upon acquisition of GNSS satellites. When the survey is completed, the receiver switches into the “Over-Determined” timing mode. In this mode, the reference position from the self-survey is maintained in memory and the receiver solves only for clock error and clock bias. The receiver provides for both Position and Time Receiver Autonomous Integrity Monitoring (T-RAIM) which allows the receiver to self-determine a position change or to remove a satellite providing incorrect information to the timing solution.

Timing Features

The timing features of the Trimble's 360 multi-GNSS timing module includes the following:

- Automatic self-survey of position for static operation
- Over-determined timing mode
- Ultra-precise one Pulse-Per-Second (PPS) output (no quantization error in *ICM SMT 360™ only*), can be configured as an even-second output, 3.3V CMOS compatible
- Disciplined 10 MHz frequency output, 3.3V CMOS compatible (*ICM SMT 360™ only*)
- Accuracy <15 ns (1 sigma) with respect to GNSS-time or UTC-time
- T-RAIM (Timing module Autonomous Integrity Monitoring)
- Position Integrity Monitoring
- Cable delay compensation
- Anti-Jamming function
- Single satellite timing mode with anti-jamming feature turned off
- Dual satellite timing mode with anti-jamming feature turned on

Other Key features

- Dimensions: 19mm width x 19mm length (0.75" x 0.75")
- Ultra-thin: 2.54mm (0.1")
- Pick and place assembly, tape and reel packaging, reflow solderable
- No I/O or RF connector, 28-edge castellations
- Two UART Serial Ports, 3.3V CMOS compatible
- World class tracking and acquisition sensitivity
- Supports Assisted-GPS (A-GPS) operation.
- Supports active antenna designs only
- Capable of simultaneously tracking of up to 32 GNSS satellites
- Supports TSIP and NMEA 0183 standard v4.1 protocols (TSIP is recommended for full timing diagnostic information)
- Carrier board and Starter Kit available
- RoHS-II compliant (lead-free)

Note – This multi-GNSS timing module is optimized for static timing applications. While it can be used in dynamic mode the stability of PPS may be degraded.

Tools and Accessories

Trimble offers a starter kit for the ICM/RES SMT 360™ timing module that makes it simple to evaluate its performance. It can be used as a platform for configuring the receiver software or as a platform for troubleshooting your design.

ICM/RES SMT 360™ is also available on a carrier board with connectors and built-in antenna-feed and –monitoring circuit for easy system integration without need for soldering the SMT module to a host PCB.

The Trimble Visual Timing Studio (VTS) software is an easy-to-use configuration and monitoring tool for use with all of Trimble’s Timing products, including ICM SMT 360™.

Use and Care

The ICM/RES SMT 360™ is a high-precision electronic instrument and should be treated with reasonable care.

CAUTION – There are no user-serviceable parts inside the ICM/RES SMT 360™ and any modification to the unit by the user voids the warranty.

Technical Assistance

If you have a problem and cannot find the information you need in the product documentation, contact the Trimble Technical Assistance Center at +1-408-481-7921 or email tsgsupport@trimble.com.

System Operation

In this chapter:

- GNSS Timing
- Time References
- Operation
- Timing module Performance
- Holdover
- Customization

This chapter describes the operating characteristics of the ICM SMT 360™ and RES SMT 360™ multi-GNSS timing module including start-up, satellite acquisition, operating modes, serial data communication, the timing pulse and the frequency output.

The Trimble's 360™ timing module acquires satellites and computes position and time solutions. It outputs data in the TSIP and NMEA protocol through its serial ports.

GNSS Timing

For many timing applications, such as time & frequency standards, site synchronization systems, and wireless voice and data networks, the ICM SMT 360™ and RES SMT 360™ can be used as the primary reference source for time and frequency. ICM SMT 360™ uses the highly accurate clock information, broadcasted from the GNSS satellites, to discipline its internal 10MHz oscillator. In addition to the stabilized 10MHz frequency output, the receiver generates a highly accurate timing pulse (PPS) from its internal clock, which is constantly corrected using the GNSS atomic clocks. This timing pulse is synchronized to GNSS or UTC time within 15 nanoseconds (1 sigma) when operating in its over-determined clock mode.*

In addition to serving as highly-accurate stand-alone time sources, GNSS timing modules are used to synchronize distant clocks in communication or data networks. This is possible because all GNSS satellites are corrected to common master clocks. Therefore, the relative clock error is the same, regardless of which satellites are used. For synchronization applications requiring a common clock, GNSS is the ideal solution.

Position and time errors are related by the speed of light. A position error of 100 meters corresponds to a time error of approximately 333 ns. This is why an accurate reference position is critical. In order to determine its accurate position, ICM SMT 360™ begins a self-survey after power-on. Using software algorithms like an over-determined clock solution, the ICM SMT 360™ mitigates the effects of clock errors to achieve PPS accuracy within 15ns (1 sigma) to GNSS or UTC after self-survey is complete.*

***Note** See detailed PPS specifications here:

[Res SMT 360 Timing Specification](#)

[ICM SMT 360 Timing Specification](#)

Time References

All GNSS satellite systems have their own master clock to which all atomic clocks inside of this system's space vehicles are synchronized. These master clocks are synchronized to the world's UTC (Universal Time Coordinated) clock ensemble, which consists of many individual atomic clocks in many countries. The synchronization among all those clock ensembles causes small steering offsets.

GNSS time differs from UTC (Universal Coordinated Time) by a small, sub-microsecond offset and an integer second offset. The small offset is the steering offset between the GNSS master clock ensemble and the UTC clock ensemble. The large offset is the cumulative number of leap seconds since 1 January 1980, which, on 30 June 2012, was increased from 15 to 16 seconds. Historically, the offset increases by one second approximately every 18—24 months, usually

just before midnight on 30 June or 31 December. System designers should note whether the output time is UTC or GNSS time.

GNSS Constellation Configuration

The ICM SMT 360™ and RES SMT 360™ can be configured to use either just one GNSS system, such as GPS, GLONASS, BeiDou, Galileo or QZSS, or a combination of these systems.

The table below shows the possible constellation options you can select

GPS	Galileo	GLONASS	BeiDou	QZSS
X				
	X			
		X		
			X	
X	X			
X		X		
X			X	
X	X			X
X		X		X
X			X	X
X				X

If a single constellation is chosen then the PPS and Time alignment will be set automatically to the same constellation.

PPS and 10 MHz Availability

Trimble cannot guarantee that the PPS is 100% available or a pulse is generated each and every second and that the frequency is continuously disciplined. The receiver’s ability to generate the PPS and to discipline the 10MHz oscillator depends on various factors, including, but not limited to, the local signal conditions at the place of antenna installation and on the health and validity of the GNSS signals that are broadcasted by the satellites. Trimble has neither control over the GNSS systems nor over the conditions at the place of installation, therefore the PPS and a valid 10MHz frequency may not be available at all times.

Start-up

The first time the Trimble’s 360™ timing module is powered-up, it is searching for satellites from a cold start (no almanac, time, ephemeris, or stored position). During the satellite acquisition process, the ICM/RES SMT 360™ outputs periodic TSIP status messages. These status messages confirm that the receiver is working.

While the receiver will begin to compute position solutions in less than one minute, the receiver must continuously track satellites for approximately 15 minutes to download a complete almanac. The almanac contains, amongst others, the UTC leap second value. ICM SMT 360™ can only compute UTC time after this leap second value was received from the satellites. Therefore, a complete and current almanac is essential for correct UTC output. The initialization process with almanac download should not be interrupted.

The ICM/RES SMT 360™ is ready to accept TSIP commands approximately 10 seconds after power-up. If a command is sent to the receiver within this 10 second window, the receiver may ignore the command. The ICM/RES SMT 360™ may not respond to commands sent within the 10 second window and may discard any associated command data.

Automatic operation

When the ICM/RES SMT 360™ has acquired and locked onto a set of satellites that pass the mask criteria listed below, and has obtained a valid ephemeris for each tracked satellite, it performs a self-survey. After a number of valid position fixes, the self-survey is complete. At that time, the ICM/RES SMT 360™ automatically switches to a time-only mode (over-determined clock mode).

Satellite masks

The following table lists the default satellite masks used by the ICM/RES SMT 360™. These masks serve as the screening criteria for satellites used in fix computations and ensure that solutions meet a minimum level of accuracy. The satellite masks can be adjusted using the TSIP protocol described in Appendix A.

Elevation and C/No masks are applied during self-survey and over-determined Clock modes. The PDOP mask however is only operable during self-survey mode.

Mask	Default-Setting	Description
Elevation	10°	Satellite elevation above horizon
C/N ₀ [dBHz]	0	Signal strength (Carrier-to-Noise power ratio)
PDOP	6	Position Dilution of Precision, used for self-survey only

Elevation mask

Generally, signals from low-elevation satellites are of poorer quality than signals from higher elevation satellites. These signals travel farther through the ionospheric and tropospheric layers and undergo distortion due to these atmospheric conditions. For example, an elevation mask of

10° excludes very low satellites from position fix computations and reduces the likelihood of potential errors induced by using those signals.

C/No mask

The quality of received GNSS satellite-signals is reported as C/N₀ value (Carrier-to-Noise power ratio). Low C/N₀ values can result from low-elevation satellites, partially obscured signals (due to dense foliage for example), or reflected RF signals (multipath).

Multipath can degrade the position and timing solution. Multipath is most commonly found in urban environments with many tall buildings and a preponderance of mirrored glass. Reflected signals tend to be weak (low C/N₀ value), since each reflection diminishes the signal.

If the ICM/RES SMT 360™ antenna has a clear view of the sky (outdoor antenna placement), a C/N₀ mask of 35dB-Hz is recommended for optimal results. However, for indoor use or operation with an obscured view of the sky, the mask must be low enough to allow valid weak signals to be used. For indoor operation, a C/N₀ mask of 0dB-Hz (zero) is recommended.

PDOP mask

Position Dilution of Precision (PDOP) is a measure of the error caused by the geometric relationship of the satellites used in the position solution. Satellite sets that are tightly clustered or aligned in the sky have a high PDOP and contribute to lower position accuracy.

The Dilution of Precision indicates the confidence level of a position fix. Low DOP values indicate a high confidence level, while high DOP values indicate a low confidence level. High DOP values are caused by poor geometry of the visible satellites. Lowering the DOP mask will exclude fixes with poor (high) DOP and will thereby improve the quality of the reference position by only accepting fixes with high confidence level. A too low DOP mask setting may, however, cause extended self-survey times, because less position fixes will pass the mask criteria, so that it takes longer to collect the amount of position fixes to complete the self-survey. The default DOP mask of ICM/RES SMT 360™ is 6. It is configurable by the user, if needed. For most applications, a PDOP mask of 6 offers a satisfactory trade-off between accuracy and GPS coverage.

Note – PDOP is applicable only during self-survey or whenever the receiver is performing position fixes.

Operating modes

The ICM/RES SMT 360™ operates in one of the following main modes:

- Self-survey mode (position fix “3D” operating mode)
- Over-determined clock mode

After establishing a reference position in self-survey mode, the ICM/RES SMT 360™ automatically switches to over-determined (OD) clock mode

Self-survey mode

At power-on, the ICM/RES SMT 360™ performs a self-survey by averaging 2000 position fixes. The number of position fixes until survey completion is configurable. The default mode during self-survey is 2D/3D Automatic, where the receiver must obtain a three-dimensional (3-D) position solution. The very first fix in 2D/3D Automatic mode must include 5 satellites or more. After a successful first fix only 4 satellites are required. If fewer than the required number of satellites are visible, the ICM/RES SMT 360™ suspends the self-survey. 3-D mode may not be achieved when the receiver is subjected to frequent obscuration or when the geometry is poor due to an incomplete constellation.

Over-determined clock mode

Over-determined clock mode is used only in stationary timing applications. This is the default mode for the ICM/RES SMT 360™ once a surveyed (or user input) position is determined. After the receiver self-surveys its static reference position, it stores the surveyed reference position to non-volatile memory and automatically switches to over-determined clock mode and determines the clock solution. The timing solution is qualified by T-RAIM algorithm, which automatically detects and rejects faulty satellites from the solution.

Using the default anti-jamming setting, a minimum of two satellites is required for a fix in over-determined clock mode. When you power-up the receiver three satellites are required for the first fix.

In this mode, the ICM SMT 360™ does not navigate or update positions and velocities, but maintains the PPS output and 10MHz disciplining, solving only for the receiver clock error (bias) and error rate (bias rate). If the anti-jamming setting is disabled, only one satellite is required for a valid timing fix.

If a stored reference position from a previous self-survey is available at startup, ICM/RES SMT 360™ will use that stored reference position and will enter the over-determined clock mode immediately after power-on. Self-survey would only be re-started if the position integrity check detects a re-location of the antenna, or if the user sends a command to change the mode or to delete the stored reference position. The over-determined clock mode can only be entered when a reference position is available to the receiver, either from a self-survey or by entering coordinates with a TSIP or NMEA command.

Integrity Monitoring

Using a voting scheme based on pseudo-range residuals, the ICM/RES SMT 360™ T-RAIM (Time Receiver Autonomous Integrity Monitoring) algorithm automatically removes the worst satellite with the highest residual from the solution set if that satellite's residual is above the current constellation average.

In addition to T-RAIM, ICM/RES SMT 360™ implements position integrity checking on startup, in case the receiver has been moved to a new location. When the receiver is powered up with a surveyed (or user input) position in memory, it will compare position fixes computed from the GNSS satellites to the surveyed position. If it finds that the surveyed position is off by more than 100meters (approximately) horizontally or vertically in the first 60 consecutive GNSS fixes, it will delete the surveyed position from memory (including non-volatile storage) and restart the self-survey.

Cable Delay Compensation

The ICM/RES SMT 360™'s default configuration provides optimal timing accuracy. The only item under user or host control that can affect the receiver's absolute PPS accuracy is the delay introduced by the antenna cable. For long cable runs, this delay can be significant. TSIP packet 0x8E-4A / NMEA packet PS sets the cable delay parameter, which is stored in non-volatile memory. For the best absolute PPS accuracy, adjust the cable delay to match the installed cable length (check with your cable manufacturer for the delay for a specific cable type). Generally, the cable delay is about 5.9 nanoseconds per meter of cable. To compensate for the cable delay, use a negative offset to advance the PPS output.

Note – *To offset the propagation delay inherent in the antenna cable typically 5.9ns per meter from the antenna to the receiver and further improve the accuracy, determine the length of the cable and enter the offset based on the specific cable type.*

Timing module Performance

ICM/RES SMT 360™ is optimized for precise time output in stationary use and will provide the best time accuracy in the over-determined clock mode. When combined with the precise cable delay compensation, this provides an accuracy of less than 15ns (1 sigma) for the PPS output with respect to GNSS time.*

***Note** See detailed PPS specifications here

[Res SMT 360 Timing Specification](#)

[ICM SMT 360 Timing Specification](#)

The time reference can be configured by the user with the 0x8E-A2 TSIP command.

The PPS time accuracy is approximately 3 times worse, around 50ns (1 sigma), when the receiver is computing position fixes during self-survey or when it's configured for 3D mode. The accuracy of the PPS is specified as a statistical Gaussian distribution. The plot below shows the likelihood function of a Gaussian distribution.

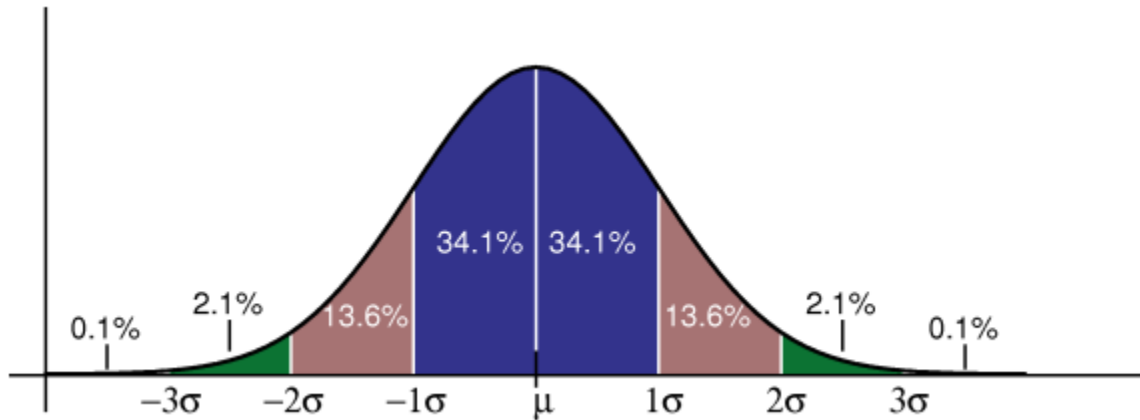

A definition of a parameter with 1 sigma (1σ) means that 68.2% of all samples are within the specified range, but 31.8% of all samples are outside. A definition with statistical notation also implies that there's no specified minimum or maximum. This applies also to Trimble's accuracy specifications of ICM/RES SMT 360™.

Acquiring the correct time

It is recommended that the time information is derived from the timing messages in the TSIP or NMEA protocols. The time reported in position packets is a time-tag for this particular position fix, but not necessarily the time of the preceding PPS pulse.

Protocol	Timing message
TSIP	Report packet 0x8F-AB
NMEA	ZDA message, ZD message

- Make sure that the almanac is complete and current and the receiver is generating 3D fixes or reporting an over-determined clock mode. This will eliminate the UTC offset jump.
- The time of the PPS pulse comes in the TSIP packet 0x8F-AB or NMEA packet ZDA+ZD following the PPS pulse.
- The leading edge of the PPS occurs on-time with the GNSS second. This can be either the rising edge (when the rising edge on-time is selected in TSIP packet 0x8E-4A) or the falling edge.

- If using TSIP, capture the time from TSIP packet 0x8F-AB. If using NMEA, capture the time from NMEA packet ZDA or ZD.
- Make sure that no alarm flags are raised by the receiver, which could indicate an uncertain or invalid time output.
- Once time is acquired, on the next PPS add 1 to the whole second to read the correct time.

Note – *The smallest time resolution is 1 second.*

Holdover stability (ICM SMT 360)

The on-board 10MHz oscillator of ICM SMT 360™ can provide holdover during short periods without reception of GNSS signals. After more than one hour of continuous GNSS disciplining and with temperature variation of less than 5°C, the PPS will be accurate within $\pm 7\mu\text{s}$ for 5 minutes without lock to GNSS satellites.

ICM SMT 360™'s built-in oscillator provides sufficient stability to provide holdover for 300 seconds. Trimble offers other products with ovenized oscillators (OCXO) that are highly stable in order to provide long-term holdover functionality.

Customizing operation

The ICM/RES SMT 360™ timing module provides a number of user configurable parameters to customize the operation of the unit. These parameters are stored in non-volatile memory (flash) to be retained during loss of power and through resets. At reset or power-up, the receiver configures itself based on the parameters stored in flash memory. A variety of TSIP packets can be used to change the values of these parameters to achieve the desired operations. The ICM/RES SMT 360™ configures itself based on the new parameter immediately, but the new parameter value is not automatically saved to flash. The save command must be manually executed to retain the changed values.

Send packet 0x8E-26 to direct the ICM/RES SMT 360™ to save the current parameter values to the flash. To save or delete the stored position, use command packet 0x8E-A6. The receiver can be set to Trimble default values by performing a factory reset by issuing TSIP command 0x1E.

In brief, to customize the ICM/RES SMT 360™ multi-GNSS timing module operations for your application:

- Configure the receiver using TSIP command packets until the desired operation is achieved.
- Use TSIP packet 0x8E-26 to save the settings in nonvolatile memory (flash).

- If the position was not automatically saved during the self-survey or if it was manually entered, the position can be saved to flash memory using TSIP packet 8E-A6.

The new settings will control receiver operations whenever it is reset or power cycled.

ICM/RES SMT 360™ Features & Specifications

In this chapter:

- Key features
- Res SMT 360 Timing Specification
- ICM SMT 360 Timing Specification
- ICM SMT 360 System Clock
- Physical Specifications
- Mechanical Drawing
- Electrical Specifications
- Mechanical Specification
- Environmental Specifications

This chapter describes the ICM SMT 360™ and RES SMT 360™ timing module's features and performance specifications.

Key Features

The ICM SMT 360™ timing module is a high performance multi-GNSS timing receiver with the PPS and 10MHz outputs.

The ICM/RES SMT 360™ is a shielded PCB assembly that comes without an enclosure. It is designed to be soldered to a host PCB and integrated within a host system to provide appropriate connections, interfaces and protection from environmental influences to the device.

The single-sided module is packaged in tape and reel for pick and place manufacturing processes: 28 reflow-solderable edge castellations provide an interface to your design without costly I/O and RF connectors. Each module is manufactured and factory tested to Trimble's high quality standards.

- Dimensions: 19 mm width x 19 mm length (0.75" x 0.75")
- Ultra-thin: 2.54 mm (0.1")
- Pick and place assembly, tape and reel packaging, reflow solderable
- No I/O or RF connector, 28-edge castellations
- World class tracking and acquisition sensitivity
- Ultra-precise 1 PPS output (can be configured as an even-second output)
- 10MHz frequency output
- Holdover of $\pm 7\mu\text{s}$ over 5 minute period (min. 1 hour learning)
- Supports Assisted-GPS (A-GPS) operation.
- Supports active antenna designs only
- Capable of simultaneously tracking of up to 32 GNSS satellites
- Supports TSIP and NMEA 0183 protocols (TSIP is recommended for full timing diagnostic information)
- Carrier board and starter kit available
- RoHS-II compliant (lead-free)

Note – *The ICM/RES SMT 360 multi-GNSS timing module is optimized for static timing applications. While it can be used in dynamic mode the stability of PPS may be degraded.*

Res SMT 360 Timing Specification

PPS: +/-15ns (1 sigma) over operating temperature range.

Res SMT 360 must be in Over Determined Mode and locked to satellites.

ICM SMT 360 Timing Specification

PPS: +/-15ns (1 sigma) at room temperature.

PPS: +/-1us (micro second) over operating temperature range.

ICM SMT 360 must be in Over Determined Mode and locked to satellites.

PPS Holdover: +/-7us (microseconds) for 300s after a learning period > 1hr

Temperature variation cannot exceed 5C during holdover.

ICM SMT 360 System Clock

Frequency: 10MHz

Enabled: After power on.

Duty cycle: 40% - 60%

Holdover stability: 100ppb

Phase noise maximum, over temperature range:

-100dBc/hz @ 100Hz

-120dBc/Hz @ 1KHz

-135dBc/Hz @ 10KHz

-140dBc/Hz @ 100KHz

Phase noise typical:

-105dBc/hz @ 100Hz

-125dBc/Hz @ 1KHz

-140dBc/Hz @ 10KHz

-145dBc/Hz @ 100KHz

Physical Specifications

Dimensions 19 mm x 19 mm x 2.54 mm

Weight 1.7 g including metal shield

Mechanical outline drawing

ICM/RES SMT 360™ multi-GNSS timing module, footprint:

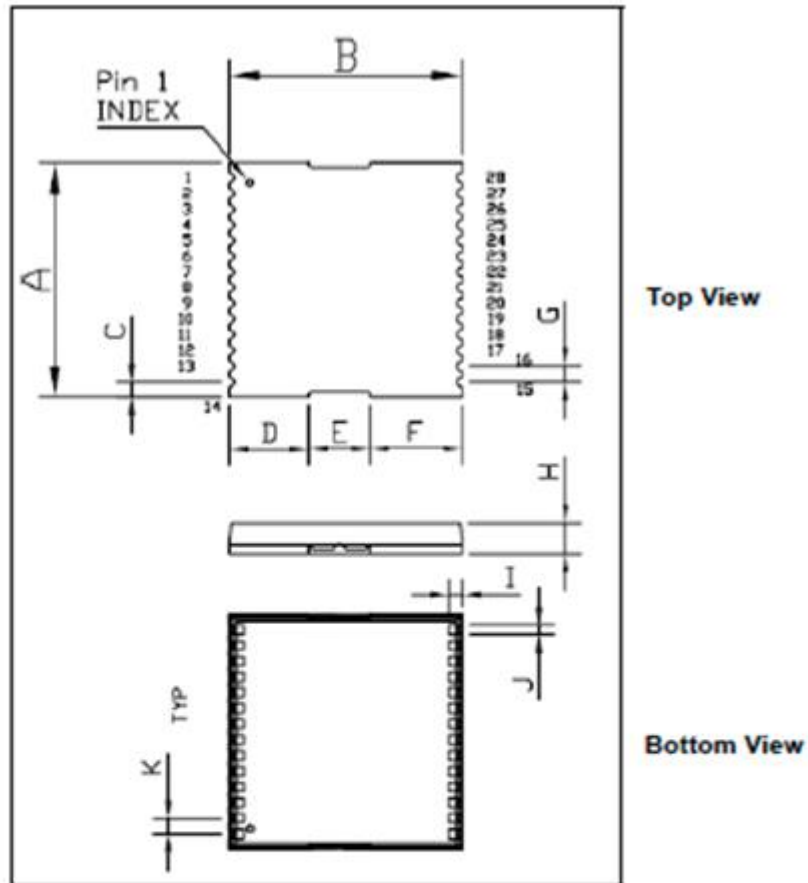

Outline Dimensions (Inch ± 0.004)
mm ± 0.10)

A	B	C	D	E	F	G	H	I	J	K
0.75	0.75	0.049	0.256	0.197	0.295	0.050	0.100	0.045	0.030	0.050
19.00	19.00	1.25	6.50	5.00	7.50	1.27	2.54	1.14	0.76	1.27

ICM SMT 360 Block diagram

ICM SMT 360 Block diagram

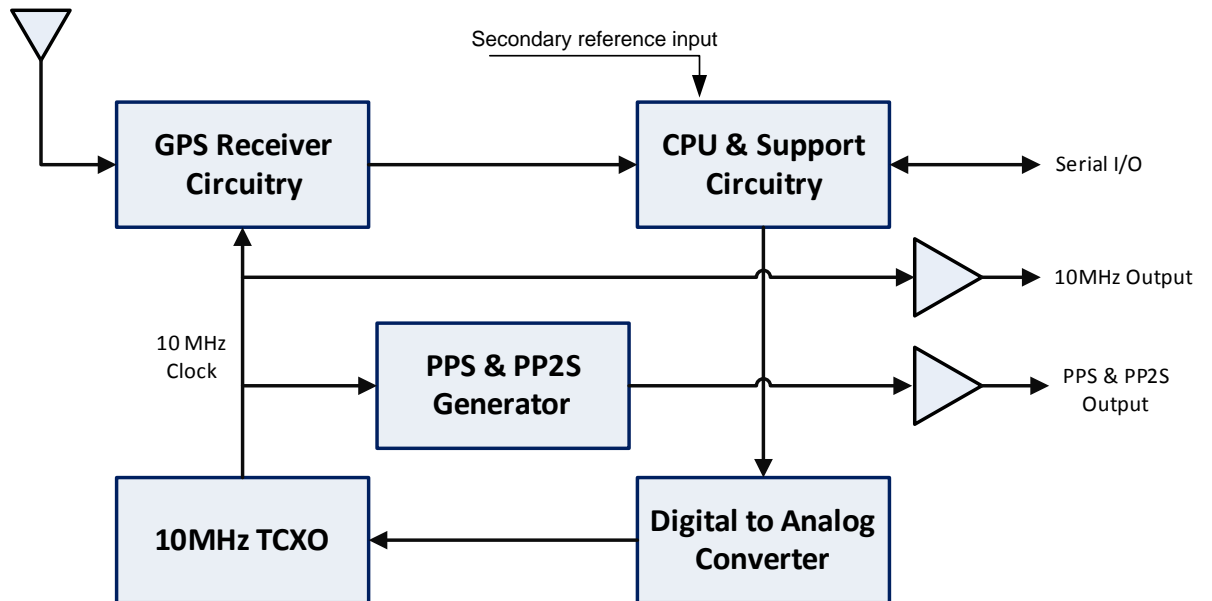

ICM SMT 360 Pin Assignment

GND	1	28	GND
GND	2	27	VCC
RFIN	3	26	GND
GND	4	25	RESET
OPEN	5	24	GND
SHORT	6	23	SYSCLK
RESERVED	7	22	TXDB
RESERVED	8	21	RXDB
RESERVED	9	20	GND
RESERVED	10	19	PPS
PPS_IN	11	18	GND
RESERVED	12	17	TXDA
RESERVED	13	16	RXDA
GND	14	15	GND

RES SMT 360 Block diagram

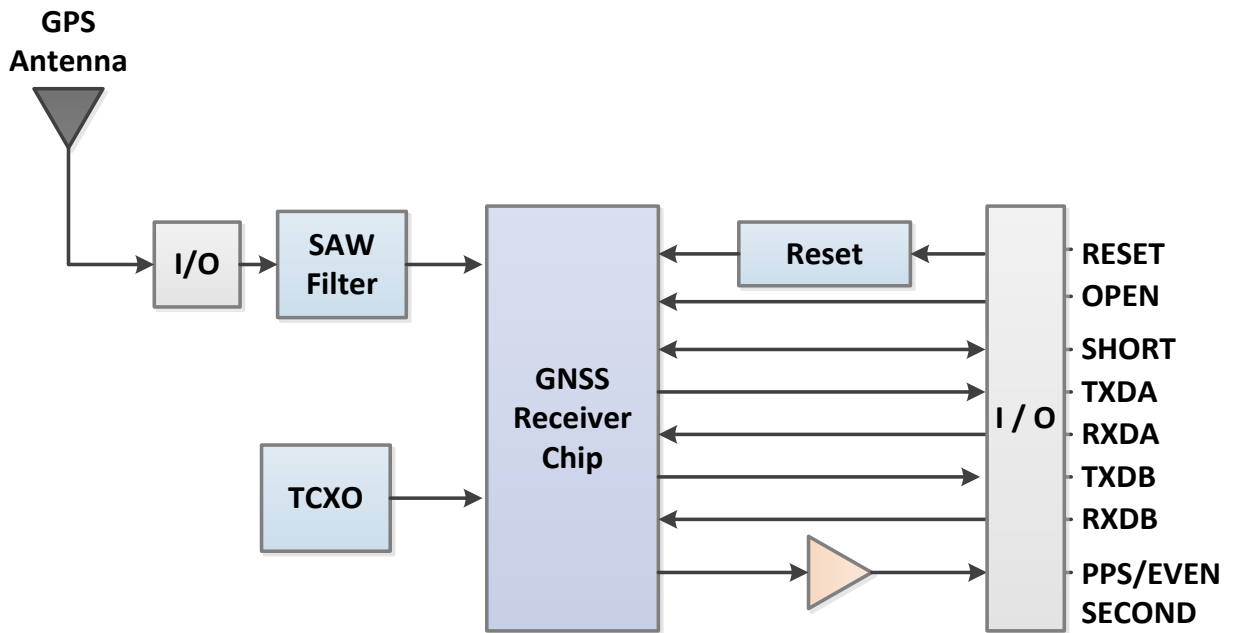

RES SMT 360 Pin Assignment

GND	1	28	GND
GND	2	27	VCC
RFIN	3	26	GND
GND	4	25	RESET
OPEN	5	24	GND
SHORT	6	23	RESERVED
RESERVED	7	22	TXDB
RESERVED	8	21	RXDB
RESERVED	9	20	GND
RESERVED	10	19	PPS
RESERVED	11	18	GND
RESERVED	12	17	TXDA
RESERVED	13	16	RXDA
GND	14	15	GND

Pin description

Pin	Name	Description	Function	Note
1	GND	Ground	Ground	Signal ground. Connect to common ground.
2	GND	Ground	Ground	Connect to common ground.
3	RFIN	GNSS RF input	Input	50 Ω unbalanced RF input.
4	GND	Ground	Ground	Connect to common ground.
5	OPEN	Antenna OPEN	Input	Logic level from external antenna detection circuit. See “Antenna Detect Truth Table”
6	SHORT	Antenna SHORT	Input / Output	Logic level from external antenna detection circuit. See “Antenna Detect Truth Table”
7	Reserved	Reserved		Do not connect
8	Reserved	Reserved		Do not connect
9	Reserved	Reserved		Do not connect
10	Reserved	Reserved		Do not connect
11	PPS_IN	Ext reference	Input	Secondary reference – <i>ICM SMT 360 only</i>
12	Reserved	Reserved		Do not connect
13	Reserved	Reserved		Do not connect
14	GND	Ground	Ground	Signal ground. Connect to common ground.
15	GND	Ground	Ground	Signal ground. Connect to common ground.
16	RXDA	UART A Receive	Input	Logic level serial port A receive
17	TXDA	UART A	Output	Logic level serial port A transmit
18	GND	Ground	Ground	Signal ground. Connect to common ground.
19	PPS/Even Second	Pulse per second	Output	Logic level Timing signal at 1 Hz. Do not connect if not used
20	GND	Ground	Ground	Signal ground. Connect to common ground.
21	RXDB	UART B Receive	Input	Logic level serial port B receive
22	TXDB	UART B Transmit	Output	Logic level serial port B transmit
23	SYSCLK	System Clock	Output	Frequency (10MHz) – <i>ICM SMT 360 only</i>
24	GND	Ground	Ground	Signal ground. Connect to common ground.
25	External Reset	Reset	Input	Active low logic level reset. If not used, do not connect.
26	GND	Ground	Ground	Signal ground. Connect to common ground.
27	VCC	Supply voltage	Power	Module power supply, 3.0 - 3.6 VDC.
28	GND	Ground	Ground	Signal ground. Connect to common ground.

Detailed pin descriptions

RFIN

The RF input pin is a 50 Ω unbalanced GNSS RF input, and can be used only with an active antenna. The VSWR of the RF input is equal or less than 2.0. Refer to the application designs for examples of antenna power circuits.

OPEN / SHORT pins

Trimble recommends that you use an antenna detection circuit that has short-circuit protection. Two pins are provided for reporting the antenna status: OPEN and SHORT. The SHORT pin usually functions as an input to monitor for short circuits. Following a short-circuit condition, it is driven high for approximately 4 microseconds in every second to turn the antenna power circuit back on.

The antenna status in the respective TSIP and NMEA packets will be reported according to the following truth table, depending on the logic levels from an external detection circuit.

Antenna reports	SHORT pin	OPEN pin
Antenna Open reported	1	1
Antenna Normal reported	1 ¹	0 ²
Antenna Shorted reported	0	0
Undefined	0	1

¹If the SHORT pin is not used it should be pulled to Vcc through a 10k Ω resistor.

²If the OPEN pin is not used it should be pulled to GND.

A typical active antenna draws between 10 mA to 20 mA. The antenna's protect/detect circuit will limit the current flow in case of a short circuit at around 100 mA. Trimble recommends that you keep the antenna current below 75 mA. An open circuit is determined if the antenna current falls below approximately 2 mA.

RESET pin

The RESET pin is an open drain input/output pin that allows the module to be forced into a reset state. This pin is normally held high by an internal pull-up resistor. It is pulled low to force the unit into a reset state. This can occur from one of three sources:

1. Internal voltage detector (with open drain driver)
2. Software reset (with open drain driver)
3. Externally pulled down by user

If used externally, this pin should be driven by an open drain or open collector driver. Alternatively, a schottky diode may be placed in series to prevent internal resets from being disabled by an external driver, and to prevent driving of user circuit by internal open drain driver.

To reset the module, drive this pin to logic level 0 or "Low" for at least 300 nanoseconds, and then release this signal. Do not continue to actively drive this pin high after reset as it might prevent software resets from working. Be aware that if a software reset is issued, then this pin will be driven low internally and drive anything connected to this line low.

This pin has an internal pull-up resistor—if this pin is not used it should be left disconnected.

Note – *When a user sends a reset to the ICM/RES SMT 360 multi-GNSS timing module the RESET pin will be pulled low for 20 microseconds.*

VCC pin

This is the primary voltage supply pin for the module.

PPS_IN pin (ICM SMT 360 only)

Input for secondary reference. Used if the GNSS signal is unavailable. A rising edge pulse of at least 50ns in width is required.

Note – *The user needs to make sure the module is locked to a GNSS constellation before using the 0x8E-A7 command to configure the external reference option.*

PPS pin

Pulse-per-second. This logic level output provides a 1Hz timing signal to external devices. The PPS pin can be configured to provide an even second output. The pulse width of this signal is fixed at 10ms.

- The cable delay compensation, enable state, and polarity can be controlled by TSIP packet 0x8E-4A.
- The PPS output options are set by TSIP packet 0x8E-4E.

RXDA, RXDB pins

This logic level input is the serial port receive line (data input to the module). The baud rate for the port is user configurable. If any of these pins are not used, they should be left disconnected.

TXDA, TXDB pins

This logic level output is the serial port transmit line (data output from the module). The baud rate for the port is user configurable.

Reserved pins

There are several reserved pins on the ICM/RES SMT 360™ multi-GNSS timing module.

CAUTION –Connecting any of the reserved pins to supply voltage or GND or any logic level may bring the ICM/RES SMT 360™ into an undefined condition that may impact the function and performance of the receiver or may cause damage to the module.

Absolute Maximum Ratings

Pin	Signal	Description	Value	Unit
27	V _{CC}	Receiver Power Supply Input	-0.3 to +3.6	Volt
2	V _I	Input Voltage	-0.3 to V _{CC} +0.3	Volt
1,4	V _O	Output Voltage	-0.3 to V _{CC} +0.3	Volt
1,2,4	I _{IO}	Input /Output Current	25	mA
3	P _{ANT}	Input Power at Antenna Input	+3	dBm

CAUTION – Absolute maximum ratings indicate conditions beyond which permanent damage to the device may occur. Electrical specifications do not apply when you are operating the device outside its rated operating conditions.

Recommended operating conditions

Minimum and maximum limits apply over the full operating temperature range unless otherwise noted.

Symbol	Parameter	Min	Typ	Max	Unit
V _{CC}	DC supply voltage (referenced to GND)	2.7		3.6	V
I _{CC}	DC supply current		100		mA
V _{IL}	Low-level input voltage			0.8	V
V _{IH}	High-level input voltage	2.0			V
V _{IL}	Low-level input voltage (RESET)			0.8	V
V _{IH}	High-level input voltage (RESET)		2.0		V
V _{OL}	Low-level output voltage			0.4	V
V _{OH}	High-level output voltage	V _{CC} -0.4			V
I _I	Input leak current			±1	µA
I _{IO}	Input/Output current			±8	mA
t _{W(RESET)}	RESET low pulse width	300			ns
R _{PU}	Pull-up resistor (RESET input)		50		KΩ

Electrical Specifications

Minimum and maximum limits apply over the full operating temperature range unless otherwise noted.

Power requirements

The operating power for the ICM/RES SMT 360™ is supplied through pin 27 of the I/O connector and the supply current return path is through pin 26, 28 and the other GND pins.

Pin	Signal	Description	Value	Unit
27	V _{CC}	Receiver Power Supply Input	-0.3 to +3.6	Volt
	V _{CC}	Receiver Operating Voltage (see Note)	3.3 ± 0.3	Volt
	I _{SUP}	Receiver Current Consumption	110	mA
	C _{SUP}	On-board Capacitance	65	μF

Note – ICM/RES SMT 360™ may not operate properly if supply voltage outside of the specified operating range is applied.

Grounding

There is a common ground plane on the ICM/RES SMT 360™ board. The ICM/RES SMT 360™ multi-GNSS timing module is designed with numerous ground pins that, along with the metal shield, provide the best immunity to EMI and noise. Any alteration by adding ground wires to the metal shield is done at the customer's risk and will void the warranty.

Serial interface

The ICM/RES SMT 360™ provides direct low-voltage (3.3V) CMOS compatible serial Input / Output (I/O). The RxD and TxD signals are driven directly by the UART on the ICM/RES SMT 360™. Interfacing these signals directly to a 3.3V CMOS-level UART in the application circuitry provides direct serial communication without the need for RS-232 or RS-422 line drivers.

Pulse-per-second (PPS)

The ICM/RES SMT 360™ provides a 10ms wide, low-voltage (3.3V) CMOS compatible Pulse-Per-Second (PPS). The PPS is available on pin 19. The leading edge of the PPS pulse is synchronized to the selected time reference (either GNSS or UTC-time). The timing accuracy is within 15 nanoseconds (1 sigma) to UTC when valid position fixes are being reported in the Over-determined Mode. See also packet 0x8E-A2 to change PPS reference to GNSS time.

A PPS pulse has to be seen in conjunction with the corresponding time tag, which is a TSIP message that is provided through the serial port. The leading edge of a PPS pulse is synchronized to the start of a full second of the selected time base with high accuracy. The TSIP

message 0x8F-AB or NMEA message ZDA, that follows a PPS pulse, contains the time and date information for this particular pulse. If TSIP message 0x8F-AB or NMEA message ZDA is configured for automatic output, it will be generated shortly after the pulse that it belongs to. If TSIP message 0x8F-AB or NMEA message ZDA, or any other packet with time information, is configured for silent mode (no automatic output), the packet that is generated in response to a query command will always refer to the PPS pulse that was preceding this packet in a 1s interval.

10MHz frequency output (SYSCLK) – For ICM SMT 360

The ICM SMT 360™ provides a low-voltage (3.3V) CMOS compatible 10MHz frequency output (SYSCLK). The SYSCLK is available on pin 23. The 10MHz oscillator of ICM SMT 360™ is disciplined using the GNSS signals as reference. The frequency output is phase-locked with the PPS pulse.

Environmental Specifications

Parameter	Condition
Operating temperature	-40°C to + 85°C
Storage temperature	-55°C to + 105°C
Vibration, operating	1.5g sine sweep from 10Hz - 1200Hz random vibration 3.06 GRMS
Vibration, non-operating	1.5g from 10Hz to 500Hz
Mechanical shock	±40g operational, ±75g non-operational
Operating humidity	5% to 95% R.H., non-condensing at +60°C
Operating altitude	-400m to 10000m Mean Sea Level

Protection against Electrostatic Discharge (ESD)

ESD testing was performed using test standard IEC 1000-4-2. All input and output pins are protected to ±500V ESD level (contact discharge).

The RF IN pin is protected up to 1 kV contact discharge. If a higher level of compliance is required, you must add additional electrostatic and surge protection.

The PCB and component areas of the ICM/RES SMT 360™ module were not tested for ESD sensitivity. The open board assembly is an electrostatic sensitive device. Appropriate care and protection against ESD, according to JEDEC standard JESD625-A (EIA 625) and IEC 61340-5-1, must be taken when handling the product.

Surge Protection

The RF input of the ICM/RES SMT 360™ is ESD protected, but not surge protected against external, larger overvoltage peaks. In order to arrest higher energy from lightning, a coax surge arrester is required, and it has to be placed at the point where the antenna cable enters the building, according to local installation regulations for rooftop antennas in the country where the antenna is installed. For more details about surge-protection, refer to the chapter about the ICM SMT 360™ Carrier Board, which contains a second level surge protection circuit.

EMI

The unit meets all requirements and objectives of FCC Part 15 Subpart J Class B.

GNSS Antenna

In this chapter:

- Antenna Requirements
- OPEN/SHORT Detection
- Antenna Placement
- Multipath
- Jamming
- Ground plane

A good GNSS antenna, together with a good installation site, is the key for getting the best performance from a GNSS receiver. This chapter explains the requirements for the antenna and provides recommendations for a good installation.

GNSS Antenna

The antenna receives the GNSS satellite signals and passes them to the receiver. The GNSS signals are spread spectrum signals in the 1551MHz to 1614MHz range and do not penetrate conductive or opaque surfaces. Therefore, the antenna must be located outdoors with a clear view of the sky. The ICM SMT 360™ requires an active antenna with integrated LNA. The received GNSS signals are very low power, approximately -130dBm, at the surface of the earth. Trimble's active antenna includes a preamplifier that filters and amplifies the GNSS signals before delivery to the receiver.

The onboard circuit of the ICM/RES SMT 360™ carrier board provides DC supply voltage on the SMB coax connector for the external, active GNSS antenna. The antenna supply voltage is fully protected against short circuit by the onboard Open/Short detection with integrated current limiter. The ICM/RES SMT 360™ carrier board has a full antenna monitoring circuit on board.

Antenna requirements

The ICM/RES SMT 360™ requires an active GNSS antenna with built-in Low-Noise Amplifier (LNA) for optimal performance. The antenna LNA amplifies the received satellite signals for two purposes:

- a) Compensation of losses on the cable
- b) Lifting the signal amplitude in the suitable range for the receiver frontend.

Task b) requires an amplification of at least 15dB, while 20dB is the sweet spot for the ICM/RES SMT 360™. This would be the required LNA gain if the antenna was directly attached to the receiver without cable in between.

The cable and connector between the antenna and the receiver cause signal loss. The overhead over the minimum required 15 dB and the actual LNA gain of the antenna is available for task a). So in case of a 30dB LNA gain in the antenna, 15 dB are available for compensating losses.

Or in other words, the attenuation of all elements (cables and connectors) between the antenna and the receiver can be up to a total of 15dB with a 30dB LNA. With a different antenna type, take the difference between 15dB and the antenna's LNA gain as the available compensation capability. Subtract the insertion losses of all connectors from the 15dB (or whatever the number is) and the remainder is the maximum loss, which your cable must not exceed.

As the GNSS signals are hidden in the thermal noise floor, it is very important that the antenna LNA doesn't add more noise than necessary to the system; therefore a low noise figure is even more important than the absolute amplification.

Trimble does not recommend having more than 35dB remaining gain (LNA gain minus all cable and connector losses) at the antenna input of the receiver module. The recommended range of remaining LNA gain at the connector of the receiver module is 20dB to 30dB with a minimum of 15dB and a maximum of 35dB.

Antenna OPEN/SHORT Detection

The ICM/RES SMT 360™ module does not have an integrated antenna feed circuit. In order to provide the required operating power to the active GNSS antenna, an external feed circuit has to be designed-in by the system integrator. The antenna feed circuit might be very basic, simply applying a DC overlay voltage to the RF line. However, it may also contain more advanced circuitry for monitoring the antenna supply status, providing current limiting in case of short circuit conditions of the antenna cable and protecting the receiver against surges on the RF-input, all of which are optional functions. Recommendations for suitable circuits are provided in the chapter 'Application Circuits' in this User Guide.

The ICM/RES SMT 360™ carrier board has an onboard antenna feed circuit, which is described in detail in the chapter about the carrier board in this User Guide

Antenna Placement

Sky-Visibility

GNSS signals can only be received on a direct line of sight between antenna and satellite. The antenna should see as much as possible of the total sky. Seen from the northern hemisphere of the earth, more satellites will be visible in the southern direction rather than in northern direction. The antenna should therefore have open view to the southern sky. If there are obstacles at the installation site, the antenna should be placed south of the obstacles, preferably, in order not to block sky-view to the south.

If the installation site is in the southern hemisphere of the earth, then the statements above are reversed – more satellites will be visible in the northern direction. Near to the equator, it doesn't matter.

Partial sky visibility causes often poor DOP values due to the geometry of the visible satellites in the sky. If the receiver can only see a small area of the sky, the DOP has a high degree of uncertainty and will be worse compared to a condition with better geometric distribution. It may happen that a receiver is seeing 6 satellites, all close together, and still get a much worse

DOP than a receiver which sees 4 satellites, but all in different corners of the sky. The receiver's DOP filter rejects fixes with high DOP (high uncertainty), therefore it can take longer to get the first acceptable fix if sky visibility is partly obstructed.

Multipath-reflections

Multipath occurs when the GNSS signals are reflected by objects, such as metallic surfaces, walls and shielded glass for example. The antenna should not be placed near a wall, window or other large vertical objects if it can be avoided.

Jamming

Jamming occurs when the receiver function is disturbed by external RF sources that interfere with GNSS signals or saturate the antenna LNA or receiver front-end. A good indicator to detect jamming is switching off all other equipment except the GNSS. Watch the satellite signal levels in this condition. Then switch on other equipment and see if the signal levels go down. A drop of signal levels indicates interference to GNSS from the other equipment. This method cannot, however, detect all possible kinds of jamming. Spurious events are hard to catch. Low frequency fields, like 50 Hz, are unlikely to jam the receiver. Broadband sparks are a potential source of spurious jamming. There's no general installation rule or specification though, because the effect of jamming highly depends on the nature of the jamming signal and there are uncountable many variations possible, so that it's not possible to standardize a test scenario.

Ground Plane

A metal plate or surface under the antenna can block signal reflections from below. This is a good method to mitigate reflections, if the receiver is mounted on high masts or other elevated sites.

Application Circuits

In this chapter:

Active antenna – no antenna status

Active antenna – antenna short protection

Active antenna – antenna open and short protection

This chapter provides several circuit examples for antenna feed and monitoring circuits to power and monitor active GNSS antennas for use with ICM SMT 360™ and RES SMT 360™.

Active antenna – no antenna status

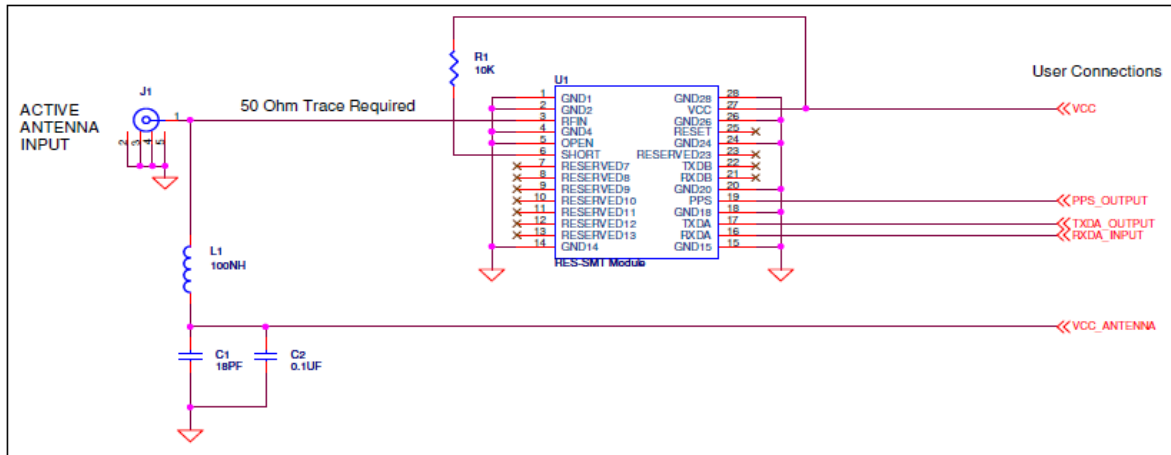

In this schematic without antenna detection:

- An active antenna is used.
- There is no hardware reset ability through the External Reset pin, as this is left disconnected.
- Antenna open and short detection or protection is not provided. If pin 5 and pin 6 are left floating, the unit reports an antenna open condition. To avoid this, pull SHORT high with a 10KΩ resistor and pull OPEN low.

The following table shows the component information:

Component	Description	Manufacturer	Part Number
C1	18PF, 0402 capacitor, C0G	KEMET	C0402C180J5GAC
C2	0.1μF, 0402 capacitor, X7R	CAL-CHIP	GMC04X7R104K16NTLF
J1	SMB Connector	Chin Nan	24-12-11-TGG
L1	100nH, 0603 inductor, surface	Coil Craft	0603CS-R10XJLU

Active antenna – antenna short protection

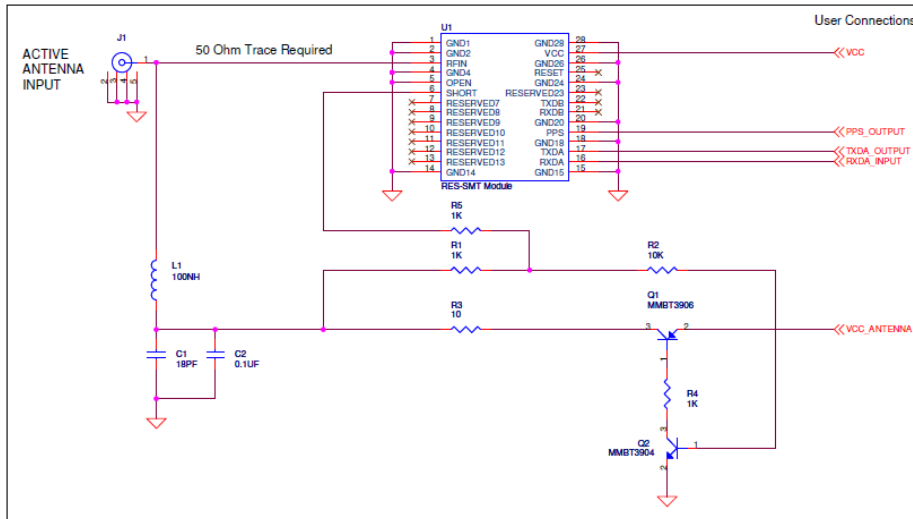

In this schematic with antenna short detection:

- An active antenna is used.
- There is no hardware reset ability through the External Reset pin, as this is left disconnected.
- Antenna short detection and protection is provided. The combination of the OPEN and SHORT pins (pins 5 and 6) report the antenna status.

The following table shows the component information:

Component	Description	Manufacturer	Part Number
C1	18PF, 0402 capacitor, C0G	KEMET	C0402C180J5GAC
C2	0.1µF, 0402 capacitor, X7R	CAL-CHIP	GMC04X7R104K16NTLF
J1	SMB Connector	Chin Nan	24-12-11-TGG
L1	100nH, 0603 inductor, surface	Coil Craft	0603CS-R10XJLU
Q1	PNP Transistor	Philips	MMBT3906
Q2	NPN Transistor	Philips	MMBT3904

Active antenna – antenna open and short protection

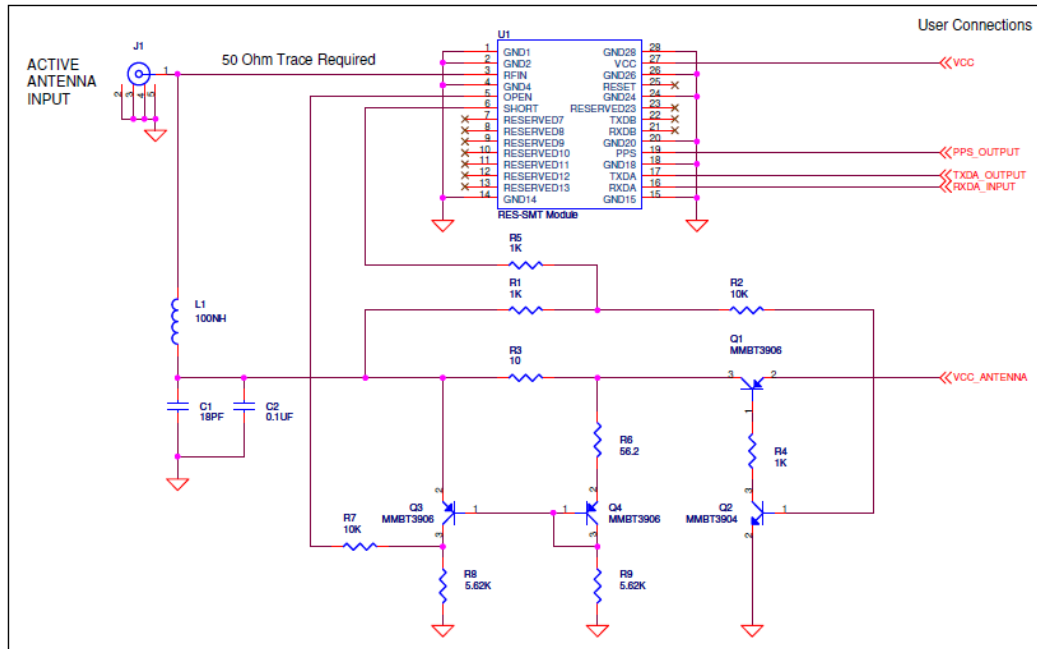

In this schematic with open and short antenna detection:

- An active antenna is used.
- There is no hardware reset ability through the External Reset pin, as this is left disconnected.
- Antenna open and short detection and protection is provided. The combination of the OPEN and SHORT pins (pins 5 and 6) report the antenna status.

The following table shows the component information:

Component	Description	Manufacturer	Part Number
C1	18PF, 0402 capacitor	KEMET	C0402C180J5GAC
C2	0.1μF, 0402 capacitor	CAL-CHIP	GMC04X7R104K16NTLF
J1	SMB Connector	Chin Nan	24-12-11-TGG
L1	100nH, 0603 inductor, surface	Coil Craft	0603CS-R10XJLU
Q1	PNP Transistor	Philips	MMBT3906
Q2	NPN Transistor	Philips	MMBT3904
Q3	PNP Transistor	Philips	MMBT3906
Q4	PNP Transistor	Philips	MMBT3906

RF Layout Considerations

In this chapter:

- General recommendations
- Design considerations for RF track topologies
- PCB considerations

This chapter outlines RF design considerations for the layout of the ICM SMT 360™ and RES SMT 360™ multi-GNSS timing module.

General recommendations

The design of the RF transmission line that connects the GNSS antenna to the ICM/RES SMT 360™ multi-GNSS timing module is critical to system performance. If the overall RF system is not implemented correctly, the ICM/RES SMT 360™ multi-GNSS timing module performance may be degraded.

The radio frequency (RF) input on the ICM/RES SMT 360™ is 50Ω, unbalanced. There are ground castellations (pins 2 and 4) on both sides of the RF input castellation (pin 3). This RF input should be connected to the output of an LNA which has a GNSS antenna as its input.

If the GNSS antenna must be located a significant distance from the ICM/RES SMT 360™ multi-GNSS timing module, the use of an LNA at the antenna location is necessary to overcome the transmission losses from the antenna to the ICM/RES SMT 360™ multi-GNSS timing module.

Determine the specifications for the external LNA as follows:

- The noise figure for the external LNA should be as low as possible, with a recommended maximum of 1.5dB. Trimble recommends that the gain of the LNA exceeds the loss that is measured from the LNA output to the module input by 15dB. For example, if the loss from the external LNA output is 10dB, the recommended minimum gain for the LNA is 25dB. In order to keep losses at the LNA input to a minimum, Trimble recommends that you connect the antenna directly to the LNA input, to ensure the minimum loss.
- To connect to the LNA output, use a 50Ω, unbalanced transmission system. This transmission system may take any form, such as microstrip, coaxial, stripline, or any other 50Ω characteristic impedance unbalanced, low-loss system.

You must keep noise sources with frequencies at or near the range from 1551MHz to 1614MHz away from the RF input. You can use a shielded transmission line system (stripline, coaxial) to route the signal if noise ingress is a concern.

To power an active antenna from the RF transmission line, you will need a bias-tee connector at the ICM/RES SMT 360™ multi-GNSS timing module end. A simple series inductor, and shunt capacitor to which the bias voltage is supplied is sufficient. Alternatively, you can use an open/short detection and over current protection circuit. See chapter 'Application Circuits' in this User Guide.

For the printed circuit board (PCB) layout, Trimble recommends that you keep the copper layer on which the ICM/RES SMT 360™ multi-GNSS timing module is mounted clear of solder mask and copper (vias or traces) under the module. This is to insure mating of the castellations

between the ICM/RES SMT 360™ GPS module and the board to which it is mounted, and that there is no interference with features beneath the ICM/RES SMT 360™ multi-GNSS timing module that will cause it to lift during the re-flow solder process.

For a microstrip RF transmission line topology, Trimble recommends that the layer immediately below the one to which the ICM/RES SMT 360™ multi-GNSS timing module is mounted is ground plane:

- Pins 2 and 4 should be directly connected to the ground plane with low inductance connections.
- Pin 3, the RF input, can be routed on the top layer using the proper geometry for a 50Ω system.

Design considerations for RF track topologies

You must take the following into consideration when designing the RF layout for the ICM/RES SMT 360™ multi-GNSS timing module:

- The PCB track connection to the RF antenna input must:
 - Have a 50Ω impedance.
 - Be as short as possible.
 - Be routed away from potential noise sources such as oscillators, transmitters, digital circuits, switching power supplies, and other sources of noise.
 - Transition from the circuit board to the external antenna cable, which is typically a RF connector, if an external antenna is used.
- The PCB track connection to the RF antenna input must not have:
 - Sharp bends.
 - Components overlaying the track.
 - Routing between components (to avoid undesirable coupling).
- RF and bypass grounding must be direct to the ground plane through its own low inductance via.

As a general guideline to prevent radiation and coupling, it helps to think of voltages and currents as electrical and magnetic fields. The electric field forms between a positive and negative charge. The magnetic field forms around a trace with current flow. You can minimize the radiation by keeping the fields under control, which means minimizing the area in which the fields form out and by separating areas with stronger fields.

- Keep the path of supply currents and their GND return currents together as close as possible. The same applies for signal currents and their GND return currents.
- Keep signal traces, which are likely to interfere with each other, apart and separate them with GND areas.

- Route supply traces and their corresponding GND return paths to separate functional blocks with separate traces and connect them only at the feed point.
- Have at least one uninterrupted GND plane on or in your PCB. The GND plane should be separated by functional blocks, but within a functional block, do not route signals across the GND plane. Route signals on another layer.
- Signal traces on a GND plane can block the way for GND return currents, thereby opening up current loops and increasing radiation. Even worse, slots in a GND plane can act as a slot-antenna structure and radiate or receive radiation on the resonating frequency.
- Surround the PCB edges with GND on top and bottom and stitch them together with multiple vias. This reduces edge radiation from traces nearby the PCB edge. On a PCB with separated GND planes, do the same on every GND area to prevent radiation from one area into another.
- Do not route signal traces across the borders of GND areas. Route them first to the GND star point and from there back to another GND area. In this way you will reduce GND coupling between the functional groups and reduce the size of the current loop, thereby reducing radiation.
- In digital circuits, lower the rising time of edges if possible. Fast rising edges (sharp square wave signals) generate many harmonics at higher frequencies. Lowering the rising time of digital outputs at the source, for example by inserting series resistors near digital output pads of ICs, will reduce the generated harmonics and therefore reduce the radiation of high frequencies.
- Always aim to minimize the sources of radiation. It is much easier and less costly to not generate radiation than to try to get rid of radiation by shielding

PCB considerations

The minimum implementation is a two-layer PCB substrate with all the RF signals on one side and a solid ground plane on the other. You may also use multilayer boards. Two possible RF transmission line topologies include microstrip and stripline.

Microstrip transmission lines

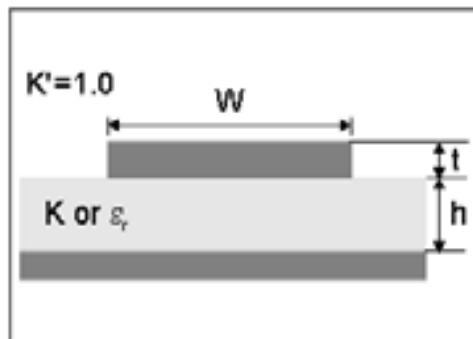

Ground plane design recommendation

Use a complete ground plane immediately under the PCB layer on which the ICM SMT 360™ timing module is mounted. On the same layer as the module, flood or “copper pour” around the signal tracks and then connect to the ground plane using low inductance vias. A single ground plane is adequate for both analog and digital signals.

Designing a microstrip transmission line

Use a 50Ω unbalanced transmission system for connections to the LNA output. The following PCB parameters affect impedance:

- Track width (W)
- PCB substrate thickness (H)
- PCB substrate permittivity (ϵ_r)
- PCB copper thickness (T) and proximity of same layer ground plane (to a lesser extent)

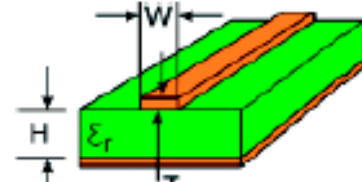

The following table shows typical track widths for an FR4 material PCB substrate (permittivity ϵ_r of 4.6 at 1.5GHz) and different PCB thickness. The thickness of the top layer is assumed as being one ounce copper. If using a multi-layer PCB, the thickness is the distance from the signal track to the nearest ground plane.

Substrate	Permittivity	Substrate thickness H	Track width W (mm)
FR4	4.6	1.6	2.91
		1.2	2.12
		1.0	1.81
		0.8	1.44
		0.6	1.07
		0.4	0.71
		0.2	0.34

Microstrip design recommendations

Trimble recommends that the antenna connection PCB track is routed around the outside of the module outline, kept on a single layer, and that it has no bends greater than 45 degrees. For production reasons, Trimble recommends that you do not route the track under the module

Stripline transmission lines

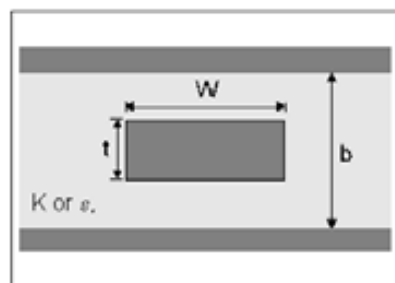

Ground plane design recommendation

The stripline topology requires three PCB layers: two for ground planes and one for signal. One of the ground plane layers may be the layer to which the ICM/RES SMT 360™ multi-GNSS timing module is mounted. If this is the case:

- The top layer must be flooded with ground plane and connected to all ground castellations on the ICM/RES SMT 360™ multi-GNSS timing module.
- The RF input should be connected to the signal layer below using a via.
- The layer below the signal layer is the second ground plane.
- Connect the two ground planes with vias, typically adjacent to the signal trace.
- Other signals of the ICM/RES SMT 360™ multi-GNSS timing module may be routed to additional layer using vias

For the symmetric stripline topology where the signal trace is an equal distance from each ground plane, the following applies:

Substrate	Permittivity	Substrate thickness H	Track width W (mm)
		1.6	0.631
		1.2	0.438
		1.0	0.372
FR4	4.6	0.8	0.286
		0.6	0.2
		0.4	0.111
		0.2	N/A

Packaging

In this chapter:

[Introduction](#)

[Reel](#)

[Weight](#)

[Tapes](#)

[Label](#)

This chapter provides detailed information about the packaging and labelling of the ICM SMT 360™ and RES SMT 360™ multi-GNSS timing module.

Follow the instructions in this chapter to ensure the integrity of the packaged and shipped modules

See the “Label” section of this chapter for the serial number format..

Introduction

The ICM/RES SMT 360™ multi-GNSS timing modules are packaged in tape and reel for mass production. One reel holds 500 modules. See the Label section of this chapter for the dimensions and serial number format.

CAUTION – The reel is sealed in a moisture proof Dry Pac bag. Please follow all the directions printed on the package for handling and baking.

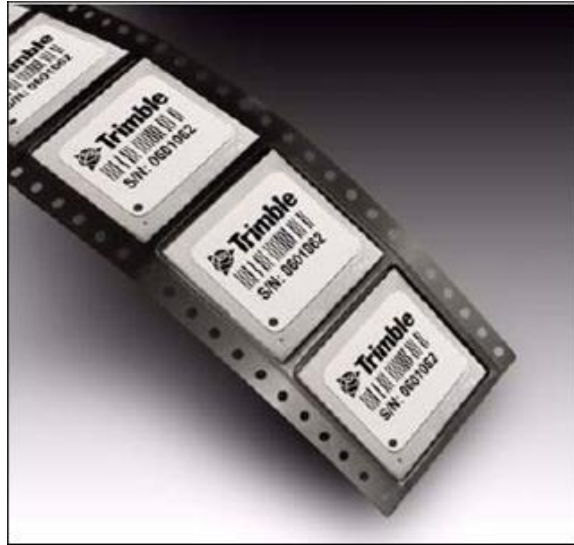

Reel

You can mount the 13-inch reel in a standard feeder for the surface mount pick and place machine

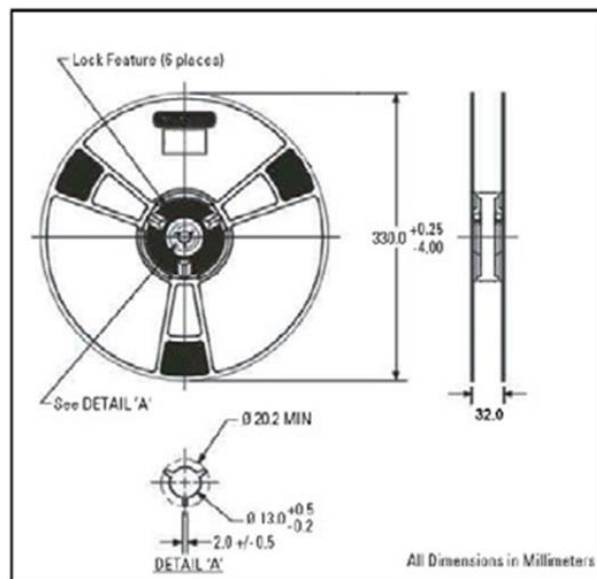

Weight

Unit description	Weight (approx.)
500 pieces with reel packaging, desiccant, and humidity indicator	1.47 Kg (3.52lb)
500 pieces with reel packaging, desiccant, humidity indicator & white carton box	1.70 Kg (3.74lb)

Tapes

The tape dimensions illustrated in the diagram below are in inches. The metric units appear in brackets [].

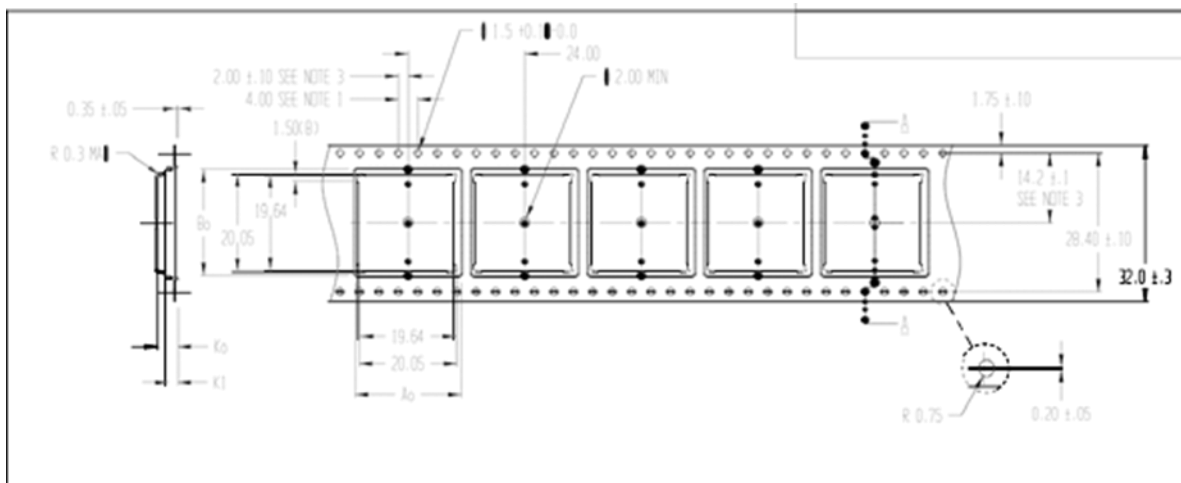

The feeding direction is illustrated below:

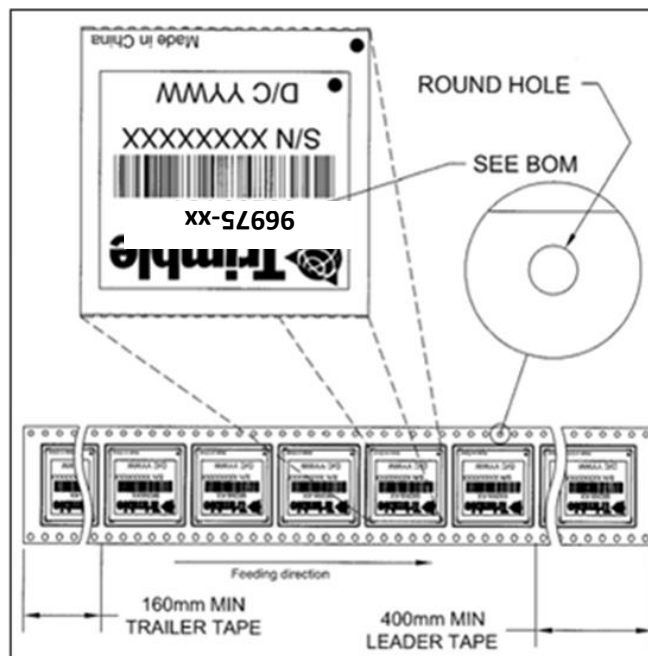

Label

The label dimensions and number format are shown in the drawing below.

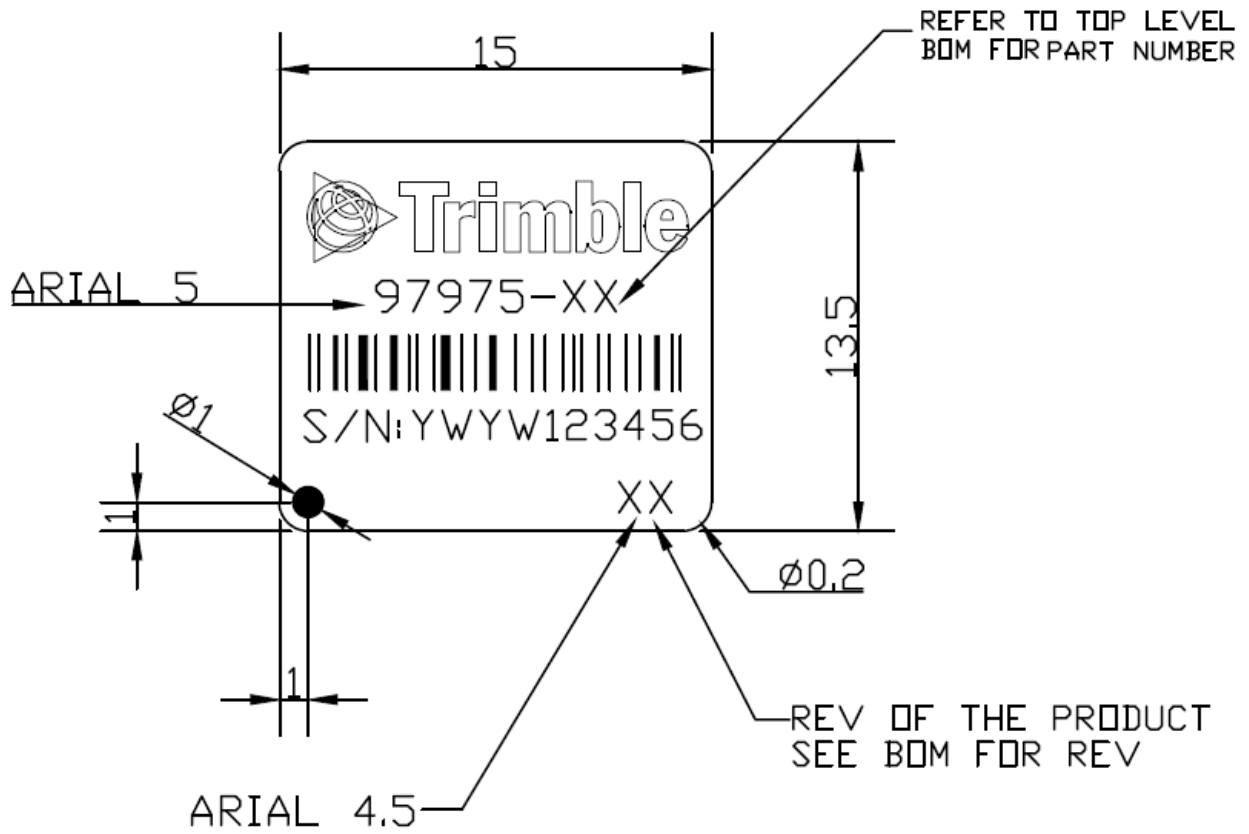

Shipping and Handling

In this chapter:

Shipping & Handling

Storage

Floor Life

Moisture precondition

Baking procedure

This chapter provides detailed guidelines for shipping and handling the ICM SMT 360™ and RES SMT 360™ multi-GNSS timing module to ensure compliance with the product warranty.

Shipping and Handling Guidelines

Handling

The ICM/RES SMT 360™ multi-GNSS timing module is shipped in tape and reel for use with an automated surface mount machine. This is a lead-free module with gold plating. Do not allow bodily fluids or lotions to come in contact with the bottom of the module.

CAUTION – The ICM/RES SMT 360™ multi-GNSS timing module is packed according to ANSI/EIA-481-B and JSTD-033A. All of the handling and precautions procedures must be followed. Deviation from following handling procedures and precautions voids the warranty.

Shipment

The reel of ICM/RES SMT 360™ multi-GNSS timing modules is packed in a hermetically sealed moisture barrier bag (DryPac) then placed in an individual carton. Handle with care to avoid breaking the moisture barrier.

Storage

The shelf life for the sealed DryPac is 12 months if stored at <40 °C and with <90% relative humidity.

Moisture Indicator

A moisture indicator is packed individually in each DryPac to monitor the environment – it has five indicator spots that are blue when the pack leaves the factory. If the indicator changes to pink, follow the instructions printed on the moisture barrier and bake as required.

Floor Life

The reel of ICM/RES SMT 360™ is vacuum sealed in a moisture barrier bag (DryPac). Once the bag is opened, moisture will bond with the modules. In a production floor environment, an open reel needs to be processed within 72 hours, unless it is kept in a nitrogen-purged dry chamber. If the moisture indicator changes to pink, follow the baking instructions printed on the moisture barrier.

The ICM/RES SMT 360™ multi-GNSS timing module is a lead-free component and is RoHS-II compliant. The pins are plated with immersion gold that makes soldering easier.

CAUTION – Operators should not touch the bottom solder pads by hand or with contaminated gloves. Ensure that no hand lotion or regular chlorinated faucet water comes in contact with the module before soldering.

Moisture precondition

You must take precautions to minimize the effects of the reflow thermal stress on the module. Plastic molding materials for integrated circuit encapsulation are hygroscopic and absorb moisture. This is dependent on the time and the environment.

Absorbed moisture will vaporize during the rapid heating of the solder reflow process, generating pressure to all the interface areas in the package, followed by swelling, delamination, and even cracking of the plastic. Components that do not exhibit external cracking can have internal delamination or cracking which affects yield and reliability.

CAUTION	4 Level
THIS BAG CONTAINS MOISTURE SENSITIVE DEVICES. Do not open except under controlled conditions. shelf life in sealed bag: 12 months @ <40C and <90% RH.	
1) Peak package body temperature 245C.	
2) After this bag is opened, devices that will be subjected to IR reflow vapor-phase reflow, or equivalent processing must be:	
a. Mounted within 72 hrs @ factory conditions of <30C/60% RH or	
b. Stored at <20% RH.	
3) Devices require baking, before mounting if:	
a. Humidity card is >20% when read at 23C+5C or	
b. 2a or 2b are not met.	
4) if baking is required, devices may be baked for 24 hrs minimum at 125C-0/+5C.	
Bag Seal Date: mm/dd/yy expiration date: 12 months from seal date.	

Baking procedure

If baking is necessary, Trimble recommends baking in a nitrogen purge oven.

Temperature 125 °C

Duration 24 hours

After baking Store in a nitrogen-purged cabinet or dry box to prevent absorption of moisture

CAUTION – Do not bake the units within the tape and reel packaging. Repeated baking processes will reduce the solderability.

Soldering Guideline

In this chapter:

- Soldering layout recommendations
- Soldering paste
- Solder reflow
- Recommended soldering profile
- Optical inspection
- Cleaning
- Soldering guidelines
- Rework
- Conformal coating

This chapter provides detailed guidelines for soldering the ICM SMT 360™ and RES SMT 360™ multi-GNSS timing module to ensure compliance with the product warranty.

Solder Pad pattern

To ensure good mechanical bonding with sufficient solder to form a castellation solder joint use a solder mask ratio of 1:1 with the solder pad. When using a 5 ± 1 Mil stencil to deposit the solder paste, we recommend a 4 Mil toe extension on the stencil.

Note – All units shown are in millimeters.

The required user pad pattern is shown below.

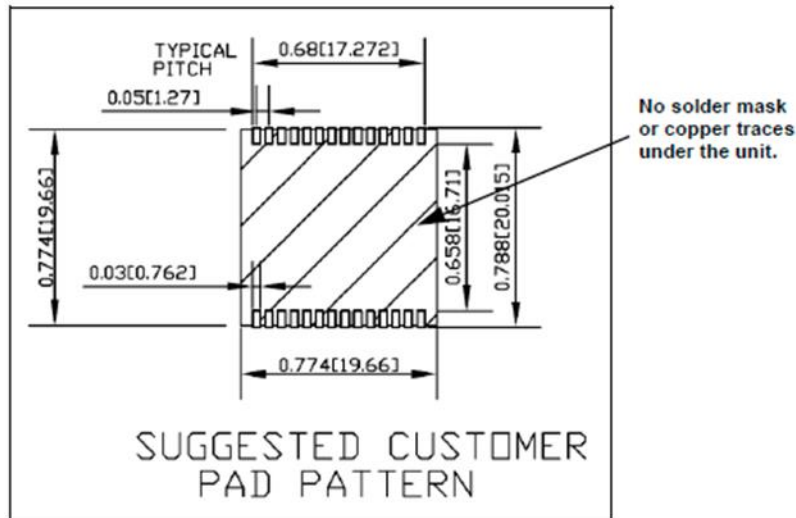

Solder mask

When soldering the ICM/RES SMT 360™ multi-GNSS timing module to a PCB, keep an open cavity underneath the ICM/RES SMT 360™ module (that is, do not place copper traces or solder mask underneath the module). The diagram below illustrates the required solder mask.

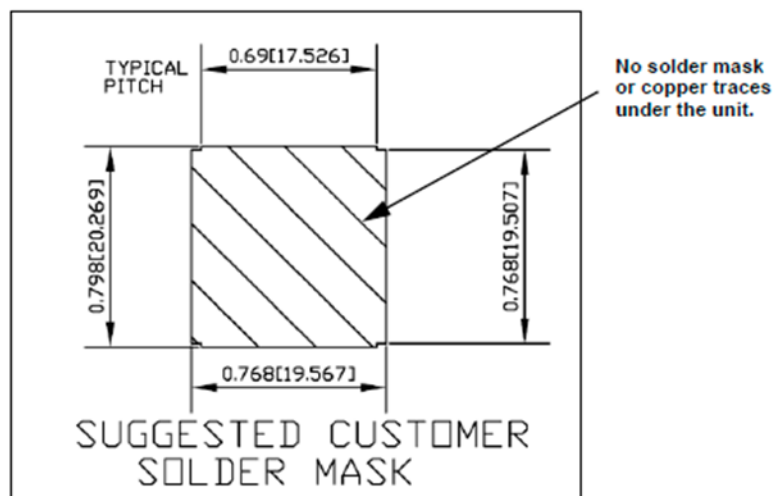

Soldering paste

The ICM/RES SMT 360™ multi-GNSS timing module itself is not hermetically sealed. Trimble strongly recommends using the “No Clean” soldering paste and process. The castellation solder

pad on this module is plated with gold plating. Use Type 3 or above soldering paste to maximize the solder volume.

Solder reflow

A hot air convection oven is strongly recommended for solder reflow. For the lead-free solder reflow, we recommend using a nitrogen-purged oven to increase the solder wetting. Reference IPC-610D for the lead-free solder surface appearance.

CAUTION – Follow the thermal reflow guidelines from the IPC-JEDEC J-STD-020C.

The size of this module is 916.9 mm³. According to J-STD-020C, the peak component temperature during reflow is 245 +0°C.

Recommended soldering profile

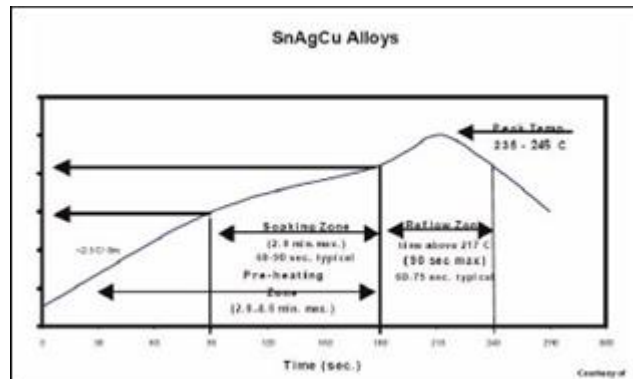

Select the final soldering thermal profile very carefully. The thermal profile depends on the choice of the solder paste, thickness and color of the carrier board, heat transfer, and the size of the panel.

CAUTION – For a double-sided surface-mount carrier board, the unit must be placed on the top side to prevent falling off during reflow.

Optical inspection

After soldering the ICM/RES SMT 360™ timing module to the carrier board, follow the IPC-610 specification and use a 3x magnification lens to verify the following:

- Each pad is properly aligned with the mount pad.
- The pads are properly soldered.
- No solder is bridged to the adjacent pads. X-ray the bottom pad if necessary.

Cleaning

When the ICM/RES SMT 360™ multi-GNSS timing module is attached to the user board, a cleaning process voids the warranty. Please use a “no-clean” process to eliminate the cleaning process. The gold-plated ICM/RES SMT 360™ timing module may discolor with cleaning agent or chlorinated faucet water. Any other form of cleaning solder residual may cause permanent damage and will void the warranty.

Orientation for reflow soldering

The liquidus temperature of the solder paste on the ICM/RES SMT 360™ module is 220°C, which means the solder will reflow during the assembly process on the host PCB, even with Trimble’s recommended temperature profile. To prevent the module falling off the host PCB during soldering, and to prevent the shield falling off the ICM/RES SMT 360™ module, it shall only be placed on the top side of the host PCB for the reflow process.

Repeated reflow soldering

The ICM/RES SMT 360™ lead-free gold plated module can withstand two re-flow solder processes. If the unit must mount on the first side for surface-mount re-flow, add glue on the bottom of the module to prevent it falling off when processing the second side.

Wave soldering

The ICM/RES SMT 360™ timing module cannot soak in the solder pot. If the carrier board is mixed with through-hole components and surface mount devices, it can be processed with one single lead-free wave process. The temperature of the unit will depend on the size and the thickness of the board. Measure the temperature on the module to ensure that it remains under 180°C. Add glue on the bottom of the module to prevent it falling off during Wave soldering.

Hand soldering

For the lead-free ICM/RES SMT 360™ timing module, use a lead-free solder core, such as Kester 275 Sn96.5/Ag3/Cu0.5. When soldering the module by hand, keep the temperature of the soldering iron below 260°C.

Rework

The ICM/RES SMT 360™ timing module can withstand one rework cycle. The module can heat up to the re-flow temperature to precede the rework. Never remove the metal shield and rework on the module itself.

Conformal coating

Conformal coating on the ICM/RES SMT 360™ multi-GNSS timing module is not allowed and will void the warranty.

ICM/RES SMT 360™ on a Carrier Board

In this chapter:

- ICM/RES SMT 360™ Carrier Board
- Mechanical specification
- Mounting
- Interface Connectors
- Power requirements
- Serial interface
- Pulse-per-second (PPS)
- 10 MHz Output (ICM SMT 360 only)
- Antenna Open/Short Detection
- Surge Protection
- GNSS antenna

ICM SMT 360™ and RES SMT 360™ are available on a carrier board with connectors for the RF antenna, power supply and I/O signals.

ICM SMT 360™ Carrier Board Visual Appearance

The pictures below are showing the visual appearance of ICM SMT 360™ Carrier Board from the top-side (component side) and the bottom-side (non-component side). ICM SMT 360™ Carrier Board is an open PCB assembly that comes without enclosure. It is designed to be integrated in a host system to provide appropriate connections, interfaces and protection to environmental influences to the device.

The Res SMT 360 Carrier Board has the same form factor as the ICM SMT 360 but will not have the 10MHz output available.

ICM SMT 360™ Carrier Board top side:



ICM SMT 360™ Carrier Board bottom side:

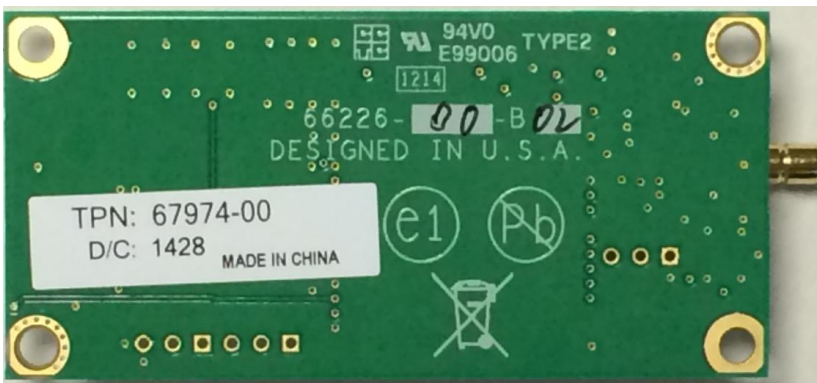

Physical Specifications

Dimensions	66.2mm x 31.8mm x 8.9mm
Weight	11g

Mechanical specification

The drawing below shows the mechanical dimensions of the ICM SMT 360™ Carrier Board. All dimensions are shown in inches and mm (in brackets []):

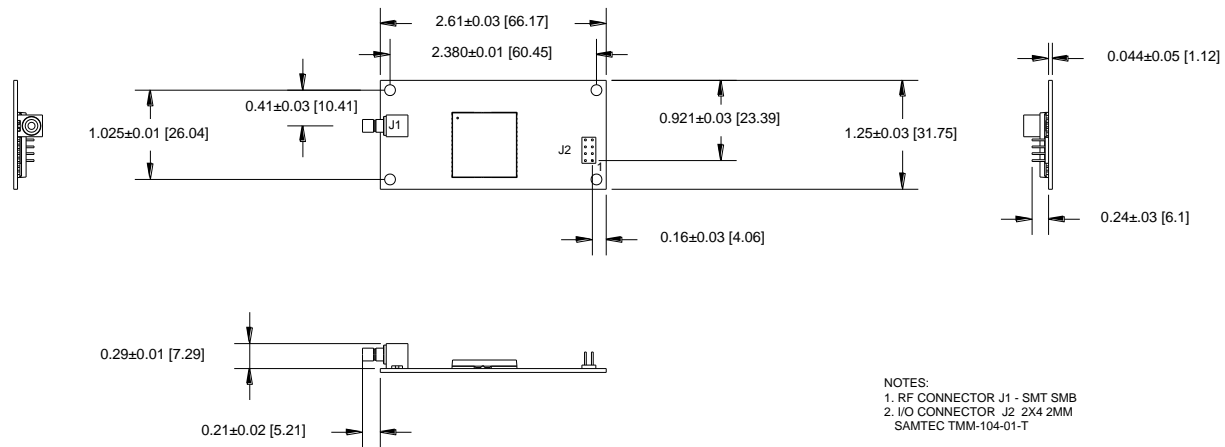

Mounting

There are four mounting holes at the corners of the PCB that accept 3/16" hex or round standoffs, and #2-2-56 or M3 mounting screws. Space constrained environments may require a different standoff. All four mounting holes are non-isolated vias which are connected to common GND.

Interface connectors

RF Antenna connector

The RF antenna connector mounted on the ICM/RES SMT 360™ PCB is a SMB Right Angle Receptacle. The contact area of this connector is gold-plated.

Digital IO/Power connector

The ICM/RES SMT 360™ Carrier Board uses a single 8-pin (2x4) male header connector for both power and data I/O. The power and I/O connector, J5, is a surface mount micro terminal strip. This connector uses 3.2mm (0.126 inch) high pins on 2mm (0.079inch) spacing. The manufacturer of this connector is Samtec, part number TMM104-01-T-D-SM

Mating connectors

A surface mount mating connector from those specified by Samtec as compatible to Samtec TMM-104-01-T-D-SM is recommended.

Digital IO/Power connector pin-out

The digital IO/Power connector pin-out information is provided in the following table:

Pin	Function	Description
1	Antenna power input	3.0V DC to 5.5V DC, 55mA max
2	Prime power input	+3.3V DC \pm 0.3V DC
3	TXDA	Port A transmit, CMOS
4	SYCLK (ICM version only)	10 MHz frequency output, CMOS
5	RXDA	Port A receive, CMOS
6	1PPS	One Pulse-Per-Second, CMOS
7	Reserved	Reserved
8	GND	Ground, Power and Signal

Power requirements

The ICM/RES SMT 360™ multi-GNSS timing module requires +3.3V DC \pm 0.3V DC at 110mA, typical excluding the antenna. The on-board capacitance is approximately 65 μ F. An important design consideration for power is the receiver's internal clock frequency at 26MHz \pm 3 KHz. Interference spurs on prime power in this narrow frequency band should be kept to less than 1mV.

The receiver does not require any special power up or down sequencing. The receiver power is supplied through pin 2 of the I/O connector. See the following table for the power specifications

CAUTION – The ICM/RES SMT 360™ multi-GNSS timing module is ready to accept TSIP commands approximately 10 seconds after power-up. If a command is sent to the receiver within this 10 second window, the receiver will ignore the command. The ICM/RES SMT 360™ multi-GNSS timing module will not respond to commands sent within the 10 second window and will discard any associated command data.

Signal	Voltage	Current	J2 Pin
VCC	3.0 - 3.6	110 mA	2
Ground	0		8

Supply voltage control

If you want to be able to power-cycle the module, you should use tri-state gates at all signal lines and PPS and SYCLK during power-down. No I/O pin should be actively driven or being pulled-high during power-down. The board may not start up as expected if pins are driven before supply voltage is switched-on.

Trimble recommends that the Off-time in case of a power-cycle is not shorter than 1s in order to allow all capacitors on the board to discharge sufficiently before the next power-on. Supply voltage dips below 3.0V or short V_{CC} outages may bring the ICM SMT 360™ into a lock-up state, which can only be resolved with a complete power-cycle.

Power-sequencing

Ideally, V_{ANT} and V_{CC} are both switched On and Off at the same time. In most designs, they're just tied together. Special sequencing is not required.

Removing V_{ANT} while V_{CC} is ON doesn't pose a problem; it just un-powers an active antenna and will raise the SHORT indicator in the TSIP and NMEA messages, but that doesn't affect the receiver's operation, except that no more satellites are being tracked with an unpowered antenna. As soon as V_{ANT} is applied again, the receiver will resume normal operation and tracking and the SHORT alarm will be removed.

V_{ANT} without V_{CC} will not back-power ICM SMT 360™, because the Open and Short signals have both a 10k in-line resistor to the I/O-pins. However, that is an undefined condition and we don't recommend powering V_{ANT} without V_{CC} in order to avoid any latch-up condition or other unexpected effects.

Serial interface

The ICM SMT 360™ multi-GNSS timing module provides direct 3.3V CMOS compatible serial I/O. The RX and TX signals on the J2 I/O connector are driven directly by the UART Port A on the ICM SMT 360™ multi-GNSS timing module. Interfacing these signals directly to a 3.3V UART in your application circuitry provides direct serial communication without the complication of RS-232 or RS-422 line drivers.

Pulse-per-second (PPS)

The ICM SMT 360™ multi-GNSS timing module provides a 10ms wide, 3.3V CMOS compatible Pulse-Per-Second (PPS). The PPS is a positive pulse available on pin 6 of the power and I/O connector J3. The rising edge (which can be configured to negative edge with the 0x8E-4A packet) of the PPS pulse is synchronized with respect to UTC. The timing accuracy is within 15 nanoseconds (1 sigma) to UTC when valid position fixes are being reported in the over-determined Mode. See also packet 0x8E-A2 to change the PPS alignment to GNSS time.

10 MHz frequency output (SYSCLK) - ICM SMT 360 only

The ICM SMT 360™ provides a low-voltage (3.3V) CMOS-compatible 10 MHz frequency output (SYSCLK). The SYSCLK is available on pin 4 of the power and I/O connector J2. The 10 MHz

oscillator of ICM SMT 360™ is disciplined by using the GNSS signals as reference. The frequency output is phase-locked with the PPS pulse.

The 10MHz output is not available on the Res SMT 360 version of the carrier board.

The PPS output can drive a load up to 15mA without damaging the receiver.

Note – No voltage shall be applied to the PPS pin while V_{CC} is off, as this can back-power the device and cause a lock-up.

Pin	Signal	Description	Condition	Min	Typ	Max
4	SYSCLK	10 MHz frequency output				
	V_{OH}	Output High Voltage	$I_{OH} = -15\text{mA}$, $V_{CC} = 3.0\text{V}$	2.4V		
	V_{OL}	Output Low Voltage	$I_{OL} = 15\text{mA}$, $V_{CC} = 3.3\text{V}$			0.4V
	I_{OH}	Output High Current Sink Capability	$V_{CC} = 3.0\text{V}$			-15mA
	I_{OL}	Output Low Current Source Capability	$V_{CC} = 3.0\text{V}$			15mA

Antenna OPEN/SHORT Detection

The circuit diagram below shows the short circuit protection and OPEN/SHORT detection circuit of the ICM SMT 360™ Carrier Board. This circuit generates the ANTOPEN and ANTSHORT hardware signals for the GNSS processor, which generates the antenna status reports in the TSIP and NMEA protocol from these hardware signals.

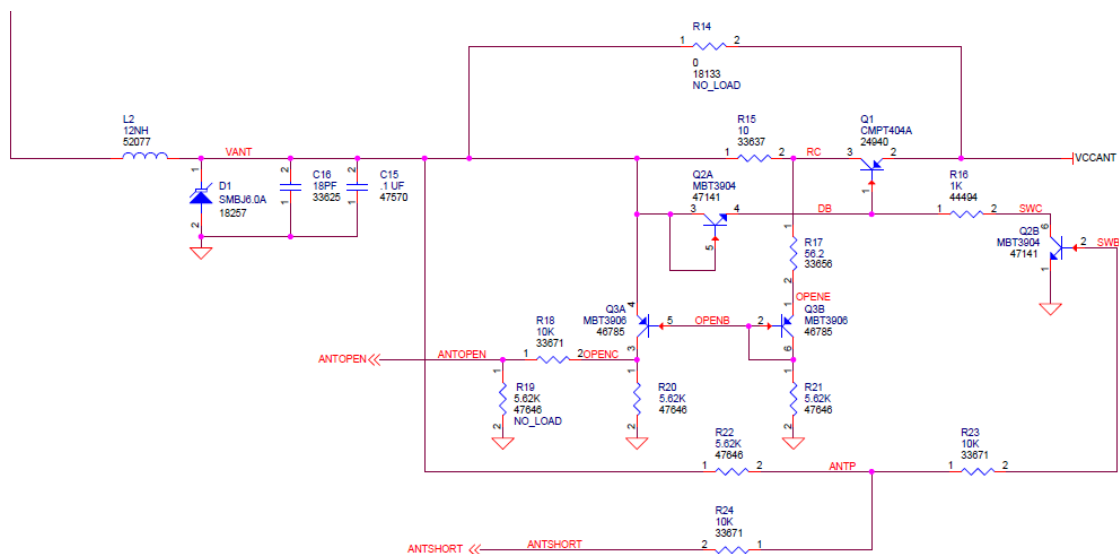

The antenna monitoring circuit is basically a current monitor with current limiting. The current limiting of ICM SMT 360™ may begin above 120mA up to approx. 190mA in a full short-circuit condition, but it's not a sharp cut-off. You will see an increasing drop of the supply voltage that goes up with the supply current. The values in the table below are dependent on component

tolerances and operating temperature and are therefore only approximate numbers and not very precise.

Antenna Voltage Feed Conditions:

V_{ANT}	Condition
+3.3V	Open: Below the 4mA to 2mA range Short Alarm: approx.80 mA Current Limiting: Above 120mA
+5.0V	Open: Below the 8mA to 4mA range Short: Above 150mA Current Limiting: Above 190mA

The antenna power input is only specified up to 5.5V (55mA). The reason for the 55mA upper limit is basically the voltage drop. Exceeding 55mA will not damage the receiver, but the antenna supply might be insufficient. The 5.5V limit shall, however, not be exceeded, because the ANTOPEN/ANTSHORT signals are routed directly to the processor, and higher voltage at those points may cause damage to the receiver due to electrical overstress.

Note - *The current-sensing circuit is causing a voltage drop between supply voltage input and antenna feed output. Voltage drops occur on transistor Q1 (current limiter to protect against short circuit condition), on the current sensing resistor R15 and on the inductor L2.*

If you're using antennas with high current consumption, the voltage drop across the sensing resistor will increase and the supply voltage at the RF-connector may drop too low to provide sufficient power to the antenna LNA. In that case, Trimble recommends using either antennas with lower operating current (preferred), or antennas with wider supply voltage range.

Surge Protection

The RF-input of ICM SMT 360™ Carrier Board is surge-protected with a TVS diode, as shown on the schematic diagram below. D1 is a 6.0V TVS diode with a peak pulse power dissipation of 600W (10/1000μs). The green line indicates the current path of a surge on the antenna center wire. A surge on the antenna shield will directly go to common GND at the coax connector of the ICM SMT 360™ Carrier Board.

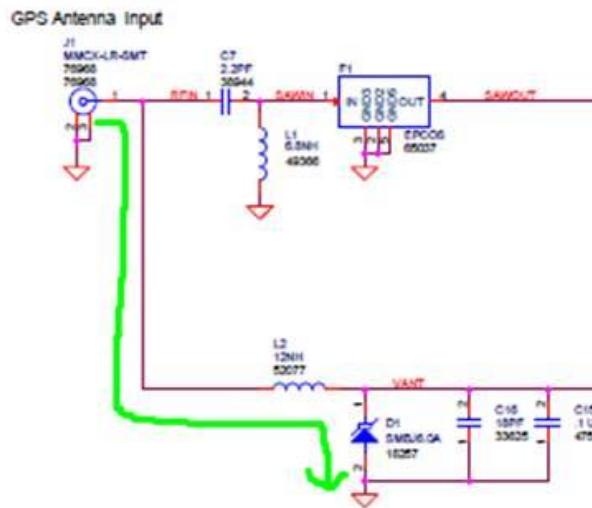

This circuit provides second-level surge protection, but it does not provide primary surge protection against lightning strikes. In order to arrest higher energy from lightning, a coax surge arrester is required, and it has to be placed at the point where the antenna cable enters the building, according to local installation regulations for rooftop antennas in the country where the antenna is installed. Trimble recommends using a fast first-level lightning protector that has 15 or 20V clamping voltage.

GNSS antenna

The antenna receives the GNSS satellite signals and passes them to the receiver. The GNSS signals are spread spectrum signals in the 1583MHz range and do not penetrate conductive or opaque surfaces. Therefore, the antenna must be located outdoors with a clear view of the sky. The ICM/RES SMT 360™ multi-GNSS timing module requires an active antenna. The received GNSS signals are very low power, approximately -130dBm, at the surface of the earth. Trimble's active antenna includes a preamplifier that filters and amplifies the GNSS signals before delivery to the receiver.

Trimble offers the following antenna options for use with the ICM/RES SMT 360™ multi-GNSS timing module.

- A 3.3V DC or a 5.0V DC Bullet GG rooftop antenna



- A 3.3V DC or a 5.0V DC Bullet 360 antenna – GPS, GLONASS, GALILEO & BEIDOU



- A 3.3V DC or a 5.0V DC Bullet GPS & BEIDOU antenna.



ICM/RES SMT 360™ Starter Kit

In this chapter:

[ICM/RES SMT 360™ Starter Kit](#)

[Content](#)

[Universal Interface Module](#)

[Powering the UIM](#)

[Timing Outputs](#)

[System requirements](#)

[Using the Starter Kit with VTS](#)

[Removing the ICM SMT 360™](#)

This chapter provides a detailed description of the Starter Kit components and usage.

ICM/RES SMT 360™ Starter Kit Content

The ICM SMT 360™ multi-GNSS Starter Kit includes all the components necessary to quickly test and integrate the receiver:



Power pin adapters



Power converter
(AC to 24VDC)



Universal Interface Module
(RS-422 to USB converter)



SMA-SMB Adapter



USB Cable

The Starter Kit includes the ICM/RES SMT 360™ Carrier Board, mounted on an interface motherboard in a durable metal enclosure. The kit also contains:

- Interface cable, USB
- AC/DC power supply adapter :
 - Input: 100 – 240 VAC
 - Output: 24 VDC
- SMB to SMA adapter cable

Universal Interface Module

The Universal Interface Module (UIM) consists of a USB interface which is compatible with most PC communication ports. Power (24 VDC) is supplied through the power connector on the front of the interface unit. The motherboard features a switching power supply which converts this voltage input to the 3.3V required by the receiver and the antenna. The USB connector allows for an easy connection to an office computer using the USB interface cable provided in the Starter Kit. The metal enclosure protects the receiver and the motherboard for testing outside of the laboratory environment.

The ICM/RES SMT 360™ Carrier Board, installed in the UIM, is a dual port receiver, but only port A is available from the carrier board header pins. A straight-in, panel-mount RF SMB connector supports the GNSS antenna connection.

The following picture shows the Starter Kit UIM:



This following picture shows the receiver in the metal enclosure:



Powering the UIM

The UIM can be powered in two alternative ways:

- From the host PC through a powered USB port
- From the AC/DC converter that it included in the Starter Kit

The ICM/RES SMT 360™ multi-GNSS timing module is designed for embedded applications and requires a regulated +3.3VDC input (+3.0 to +3.6VDC). The receiver provided in the Starter Kit is installed on a motherboard, which provides a DC power regulator which converts a 24VDC input from the power connector or a 5VDC input from the USB connector to the regulated 3.3VDC required by the receiver and the antenna.

AC/DC power converter

The AC/DC power converter may be used as an alternate power source for the interface unit if no sufficient 5 VDC is available from the USB host. The AC/DC power converter converts 110 or 240VAC to a regulated 24VDC compatible with the UIM. The AC/DC power converter output cable is terminated with a connector compatible with the power connector on the metal enclosure. The AC supply comes with a range of clip-on adapters for international use.



Pulse-per-second (PPS)

The Pulse-Per- Second (PPS) is available on the BNC connector of the UIM.

10 MHz Frequency Output (*ICM SMT 360 only*)

The 10 MHz frequency output of ICM SMT 360™ is only available on the connector of the ICM SMT 360™ carrier card. In order to access the SYSCLK output of the Starter Kit you need to open

the UIM enclosure and run a wire to the SYCLK pin of the I/O connector J2 of the ICM SMT 360™ carrier card.

Note – The ICM SMT 360™ on carrier board product (67974-xx) will have the SYCLK on pin #4.

System requirements

Hardware

- The Trimble ICM/RES SMT 360™ Starter Kit
- User-provided equipment to analyze the PPS accuracy and a BNC connector to connect it to the ICM/RES SMT 360™ Starter Kit.
- A PC with Microsoft Windows XP or higher (tested up to Windows 8.1)

Software

- Trimble's Visual Timing Studio (VTS)

Using the ICM/RES SMT 360™ Starter Kit with VTS

Please refer to the VTS User Guide for more information about the functions of VTS, which is Trimble's universal monitor and configuration tool for the Timing products, including ICM SMT 360™. VTS and the User Guide are available for download on Trimble's website: www.trimble.com/Timing/.....

Removing the ICM/RES SMT 360™ Carrier Board from the UIM

WARNING – Before opening the interface unit, disconnect the unit from any external power source and confirm that both you and your work surface are properly grounded for ESD protection.

The ICM SMT 360™ Carrier Board is attached to the motherboard standoffs with Phillips head screws, allowing for removal and integration with the user's application. Follow these steps to remove the receiver from the UIM motherboard:

1. Disconnect power and USB from the enclosure.
2. Remove the base plate and unplug the RF cable from the receiver.
3. Use a small Phillips screwdriver to remove the securing hardware which holds the ICM SMT 360™ carrier board to the motherboard.
4. Gently slip the board loose from the motherboard I/O connector

Software Interface

In this chapter:

Start-up

Communicating with the receiver

Port protocol and data output options

This chapter describes the software interface and describes communication with the receiver, port protocol, and data output options.

Note: Trimble recommends that the TSIP protocol is used for all timing functions due to the availability of timing specific status and alert messages.

NMEA is made available for the convenience of the user but this protocol does not provide the same status and alert features.

Communicating with the receiver

The ICM/RES SMT 360™ multi-GNSS timing module supports two message protocols: TSIP and NMEA. Communication with the receiver is through serial ports. The port characteristics can be modified to accommodate your application requirements. The protocol settings and options are stored in Random Access Memory (RAM). They can be saved into the non-volatile memory (Flash), which does not require back-up power, if required, using command 0x8E-26.

Protocols

The following protocols are available on the ICM/RES SMT 360™ multi-GNSS timing module:

Protocol	Specification	Direction
TSIP	Trimble proprietary binary protocol	Input / Output
NMEA	NMEA 0183 v4.1	Input ¹ / Output

¹Requires use of Trimble-proprietary NMEA messages.

Serial port default settings

The ICM SMT 360™ multi-GNSS timing module supports two serial ports. The default settings are as follows:

Port	Port Directions	Pin #	Protocol	Characteristic				
				Baud rate	Data bits	Parity	Stop bits	Flow control
A	TXDA	17	TSIP out	115 kbps	8	Odd	1	None
	RXDA	16	TSIP in	115 kbps	8	Odd	1	None
B	TXDB	22	Not set ¹	115 kbps	8	Odd	1	None
	RXDB	21	Not set ¹	115 kbps	8	Odd	1	None

¹ Use the TSIP 0xBC command on Port A to configure protocol for Port B, and then use the TSIP 0x8E-26 command to save the configuration.

- Baud rate, data bits, parity, and stop bits are user configurable.
- Flow control is not available on the serial ports.

Detailed descriptions of these protocols are defined in the Appendices A and B of this User Guide

Note – The ICM/RES SMT 360™ Carrier Board and Starter Kit only bring Port A for TSIP to the connector.

CAUTION – When changing port assignments or settings, confirm that your changes do not affect the ability to communicate with the receiver (e.g., selecting the PC COM port settings that do not match the receiver's, or changing the output protocol to TSIP while not using VTS).

Software tools

Any standard serial communications program can be used to view the ASCII NMEA output messages. TSIP is a binary protocol and outputs raw binary serial data that cannot be read when using a Terminal program. To view the output of the TSIP protocol in text format, use the Trimble Visual Timing Studio (VTS) program.

VTS, a Windows-based GUI, provides a versatile graphical interface for monitoring TSIP and NMEA data. This application allows the user to view complete receiver operations including data output, status and configuration. In this application, the entry of command packets is replaced by traditional point and click pull-down menus.

Assisted GPS (A-GPS)

In this chapter:

[A-GPS Overview](#)

[A-GPS Operating Modes](#)

[TSIP for passive A-GPS](#)

[A-GPS with VTS](#)

The ICM SMT 360™ and RES SMT 360™ multi-GNSS receiver supports assisted GPS (A-GPS), which allows the receiver to obtain a position fix even in very poor GNSS signal conditions using almanac, ephemeris, time and position data.

Note that this feature applies to only the GPS constellation.

Assisted GPS (applies to GPS constellation only)

The ICM/RES SMT 360™ multi-GNSS receiver supports Assisted GPS (A-GPS), which allows the receiver to obtain a position fix even in very poor GNSS signal conditions using almanac, ephemeris, time, and position data.

When attempting to acquire GNSS the SNR ratio (C/No) must be high enough so that the signal may be detected. Since all GNSS systems utilize spread-spectrum techniques it is possible to dwell for longer periods of time to improve tracking in low C/No situations. The problem is that, if the dwell period is too long, the information being transmitted by the satellites cannot be accurately decoded. A-GPS provides *"initial time and position information"* as well as the data that is being transmitted by the satellites to the receiver through the serial interface. This allows the receiver to acquire at levels that are normally only available for tracking.

The A-GPS source could be another Trimble receiver that has downloaded the data already, or a server that can provide the current data-set as a file. To ensure the proper format of the ephemeris file and almanac file, you must use a Trimble receiver to gather this data. Almanac files from non-Trimble receivers may not be in proper format and thus may not work (e.g. if almanac files are downloaded from the Internet).

You can download the current almanac, ephemeris, time, and position information from an operational Trimble receiver, and then upload this data to the module using either the Trimble VTS application for Windows or the TSIP protocol with your own application software.

Most receivers specify a lower tracking level than an acquisition level. This is because the data has already been acquired so the unit is able to track down to levels where the data cannot be reliably decoded. This lower tracking level is, historically, caused by GNSS being on a moving platform where the signal level is not constant. Allowing a lower tracking level allows the unit to still derive accurate positioning, even though new data cannot be decoded. The unit is not expected to operate continuously in this mode. With A-GPS providing the data, however, the unit is able to continuously track at these lower levels.

Prerequisites for the Trimble A-GPS solution

What is unique to Trimble is the amount of error that can be present in the information provided before acquisition can be achieved. Trimble's A-GPS solution requires that the time be given to the system, accurate to within 3 seconds, as well as an initial position approximation, within **3000km**. The initial position error far exceeds any other A-GPS specification, normally around **300-3000m**, but it does require that the unit has at least one satellite that is at a minimum of -140dBm signal level. With those requirements all other satellites can be as low as -153dBm. The requirement of a single satellite that is at, or above a pilot level is based on the 3GGP TS 25.171 specification. The initial position error equates to a large timing error: 3000km

= 3,000,000m, if we assume light travels at approximately 300,000,000 m/s that gives us an initial timing error of $3e6/300e6 = 1/100 = 0.01s$, or 10ms. The stronger satellite allows the unit to decode the time from satellites and still remove millisecond ambiguities.

Note that if the initial position error is less than 300m then all satellites can be in the -153dBm range.

Normal acquisition is improved to -153dBm. Because of the low-level of the signals acquisition takes considerably longer than a unit with strong signals available. The unit is designed for a specification of 90% of the time the unit acquires the satellites, and starts generating fixes, within 600 seconds of start-up. The acquisition time drops as the initial position accuracy improves. With 1000km error our testing show the TTFF improves to around 300 seconds.

A-GPS Operating Mode

To Request time and position, the ICM will send packets 0x2E and 0x2B. The user's response to these packets will also be 0x2E and 0x2B.

To request system data (almanac, UTC, ionosphere and ephemeris), the ICM will send packet 0x38. ICM will use "0xFF" in the SV byte to tell the user to send the almanac or ephemeris for all SVs. The user will respond with packet 0x38 (1 SV per packet).

Aiding Data Type	Packet ID	Description
Time	0x2E	Request/Set GPS time
Position	0x2B	Request/Set Accurate Position
Almanac	0x38	Request/Load Satellite System Data
Ephemeris	0x38	Request/Load Satellite System Data

The ICM SMT 360™ use passive mode to receive aiding data from the A-GPS server. In this mode, the receiver does not send any request of TSIP packets to the A-GPS server. The A-GPS server is responsible for scheduling when to send aiding data to the receiver. The rule is that time & position are sent first. After ICM/RES SMT 360™ receives the time & position, the A-GPS server can send the almanac about once a day and sends the ephemeris about every 1 hour.

A-GPS TSIP Message Flow Illustration

1. Time

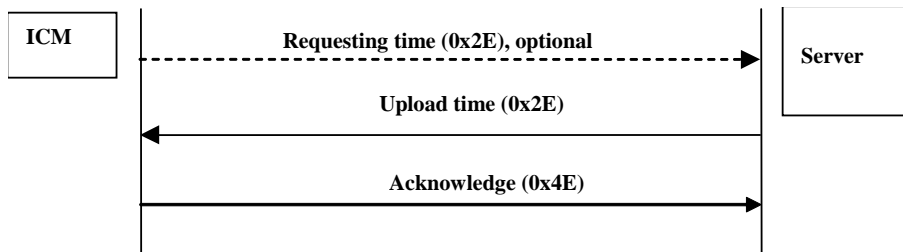

2. Position

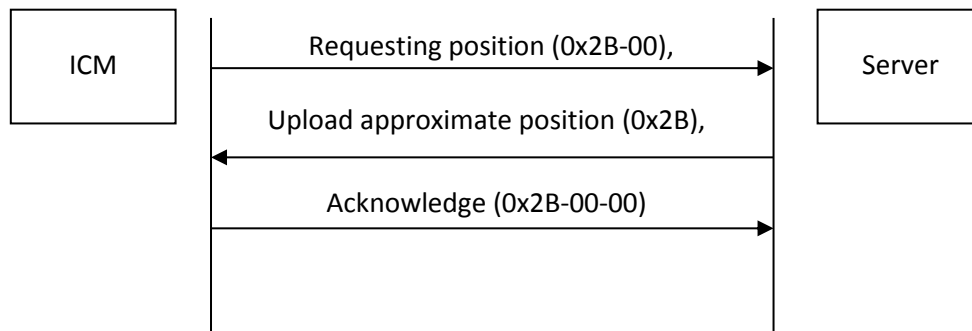

3. Almanac

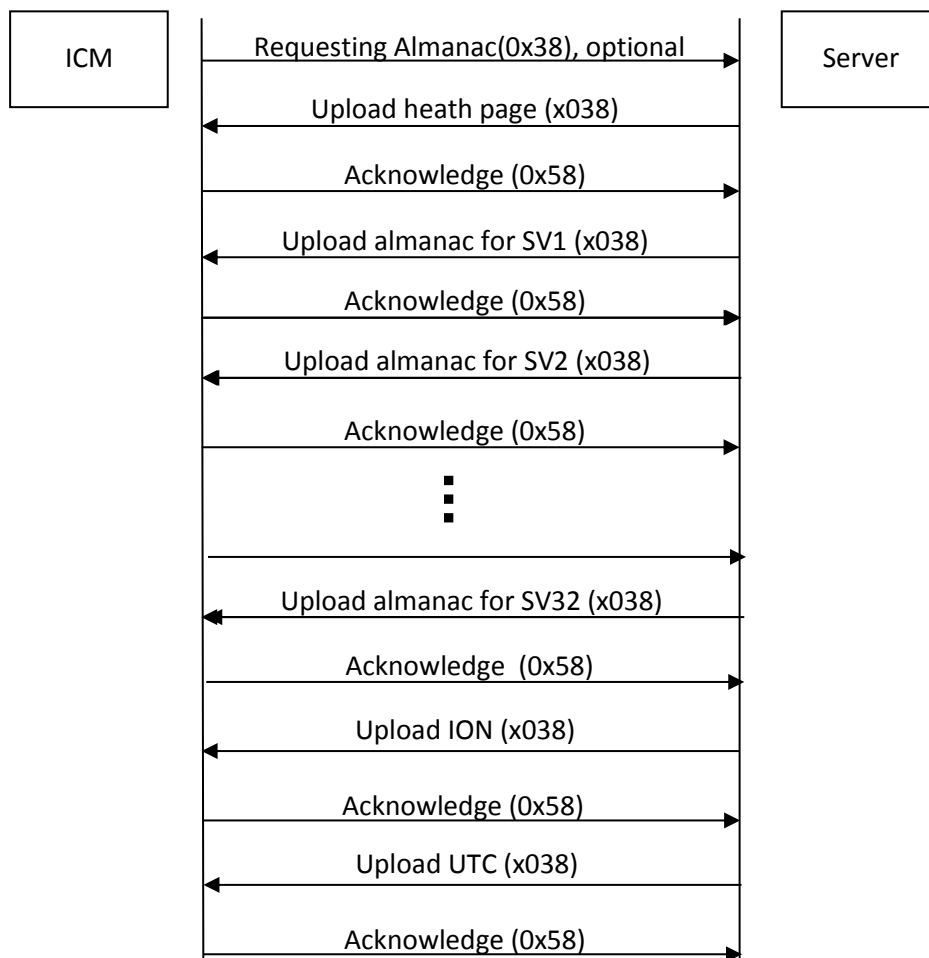

4. Ephemeris (Request all SVs in once)

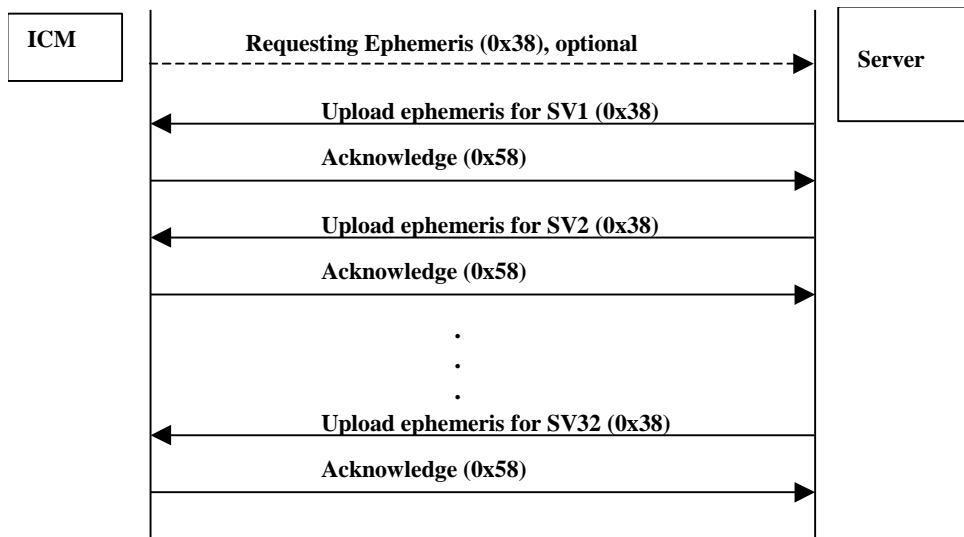

5. Ephemeris (Request for individual SV)

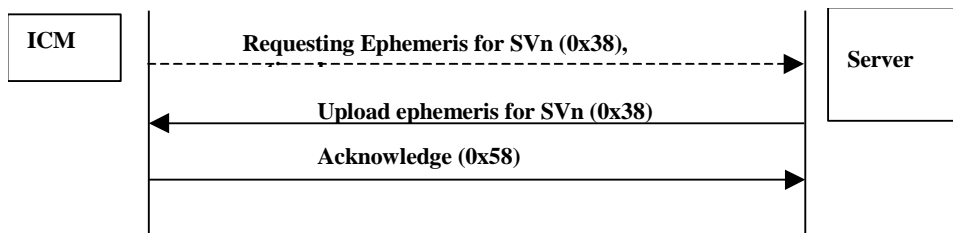

Note – 1: Request packet originated from ICM/RES are optional based on the aiding request mode.

Note – 2: Request almanac packet is always to request all almanac information including almanac data for all SVs, Ionosphere and UTC.

Note – 2: For aiding request mode #1, requesting ephemeris is always to request ephemeris data for all SVs. In other two modes, server can send ephemeris for individual SV.

A-GPS with the Trimble Visual Timing Studio (VTS) application

To collect A-GPS data from an ICM/RES SMT 360™ receiver and to initialize the same or another receiver with the stored data at a later time proceed as follows:

1. Attach the ICM/RES SMT 360™ GNSS interface unit to your computer.
2. Place the GNSS antenna where there is a clear view of sky.
3. Allow the receiver to run and calculate fixes.
4. Start VTS and then connect to the receiver.

- On the main monitor screen, wait for the almanac field to indicate “Complete”. This confirms that the receiver has collected a current almanac.

Note – It takes the ICM/RES SMT 360™ unit 12.5 minutes of uninterrupted operation to collect an almanac from the satellites.

- In the Monitor window, select Receiver /Load A-GPS Data. In the Action group, select Get from receiver to download the almanac, position, time, and ephemeris files to your computer:

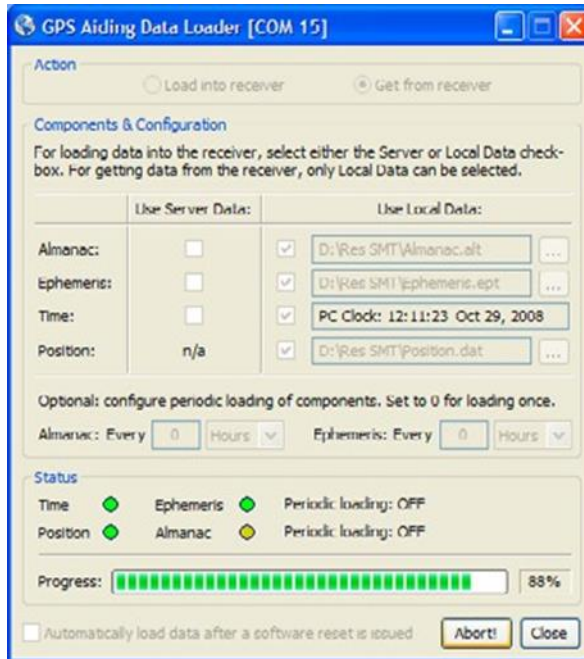

- When you have collected these files, use them the next time the receiver is started up to assist signal acquisition: Select *Receiver /Load A-GPS Data* again. In the *Action* group, select the *Load into receiver* option to upload the files:

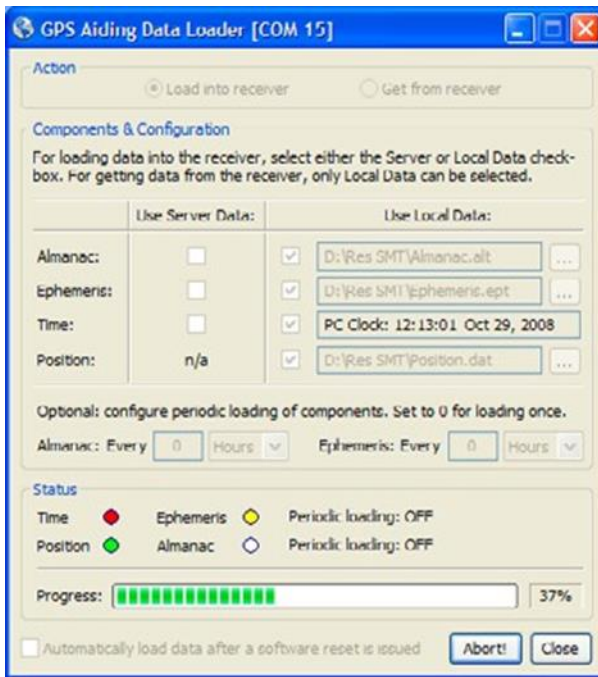

Note – The collected ephemeris is only valid for approximately 2 hours.

The easiest way to initialize the ICM/RES SMT 360™ with A-GPS data is using Trimble’s webserver that hosts the latest A-GPS data files. A working Internet connection is required for this method. Just set the checkmarks in the ‘Use Server Data’ checkboxes and VTS will pull the A-GPS files automatically from Trimble’s webserver and load them into the ICM SMT 360™.

Enabling A-GPS with TSIP

1. Allow the receiver to run long enough to collect a current almanac.

Note – It takes the ICM/RES SMT 360™ unit 12.5 minutes of uninterrupted operation to collect an almanac from the satellites.

2. Use packet 0 x 26 to request the health of the receiver. The receiver responds with packets 0x46 and 0x4B if the almanac is complete and current. Wait until packet 0x4B indicates that the almanac is complete before continuing.
3. Use packet 0x38 to request the almanac and the ephemeris for each of the 32 GPS satellites. The receiver responds with packet 0 x 58.
4. Use packet 0x8F-AB to get the current GPS time from the receiver. You can use this data to set your own off-board clock.
5. Use packet 0x8F-AC to get a position from the receiver.

To upload this information to the receiver:

1. Upload the time using packet 0x2E. Wait for upload confirmation report packet 0x4E.

2. Upload the position using packet 0x2B. The confirmation report packet 0x2B is returned.
3. Upload the ephemeris using packet 0x38. Wait for upload confirmation report packet 0x58.

See also Appendix A, Trimble Standard Interface Protocol

Trimble Standard Interface Protocol

In this chapter:

- Introduction
- Customizing operations parameters
- Packets output at startup
- Report packets: ICM/RES SMT 360™ to User
- Command Packets: User to ICM/RES SMT 360
- Packet structure
- Packet descriptions
- TSIP Superpackets
- Unused or miscellaneous packets
- Legacy packets (unused)

The Trimble Standard Interface Protocol (TSIP) may be characterized as a set of data packets used to transmit information to and receive information from a Trimble GPS receiver. Trimble products commonly support a version of TSIP which is customized to the attributes of the product. This appendix describes the ICM SMT 360™ and RES SMT 360™ customization.

WARNING – The ICM/RES SMT 360™ multi-GNSS timing module is ready to accept TSIP commands approximately 10 seconds after power-up. If a command is sent to the receiver within this 10 second window, the receiver will ignore the command. The ICM/RES SMT 360™ multi-GNSS timing module will not respond to commands sent within the 10 second window and will discard any associated command data.

Note – This appendix has been generated and reviewed with care, however, history has shown that it is surprisingly difficult to generate a TSIP appendix which is entirely free of errors. There is no reason to believe that this appendix will be an exception. Trimble is always grateful to receive reports of any errors in either products or documentation.

Introduction

TSIP is a powerful and compact interface protocol which has been designed to allow the system developer a great deal of flexibility in interfacing to a Trimble product. Many TSIP data packets are common to all products which use TSIP. An example would be a single precision position output packet. Other packets may be unique to a product. Custom packets are only used in the products for which they have been created.

Interface scope

The ICM/RES SMT 360™ multi-GNSS timing module has one configurable serial I/O communication port, which is a bi-directional control and data port utilizing a Trimble Standard Interface Protocol (TSIP). The data I/O port characteristics and other options are user programmable and stored in non-volatile memory (Flash memory).

The TSIP protocol is based on the transmission of packets of information between the user equipment and the GPS receiver. Each packet includes an identification code that identifies the meaning and format of the data that follows. Each packet begins and ends with control characters.

TSIP (Trimble Serial Interface Protocol) Packet Structure

The basic structure of a TSIP packet is the same for both command and report packets.

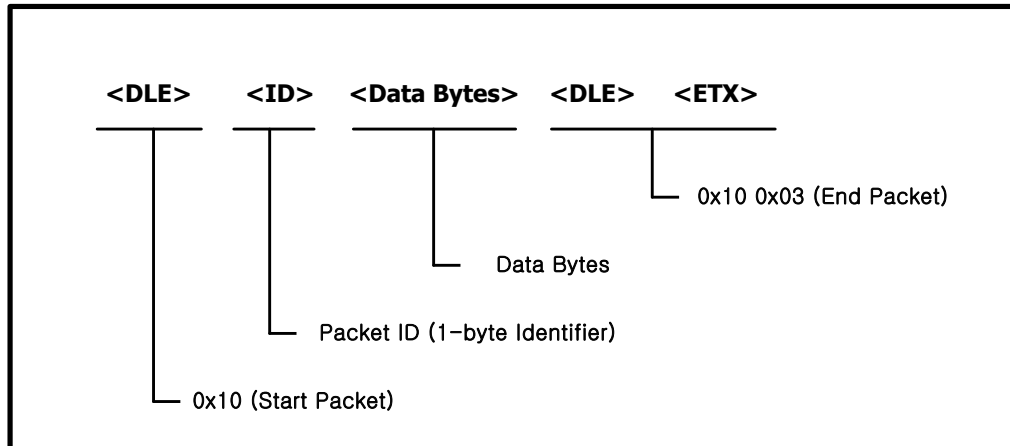

Figure 1-1: TSIP Packet Structure

<DLE> is the byte 0x10

<ETX> is the byte 0x03 and

<ID> is a packet ID byte, which can have any value with the exception of <ETX> and <DLE>.

The values of the data bytes vary and are dependent on the function performed by the packet. To prevent confusion with the starting and ending frame sequences, <DLE> <ID> and <DLE> <ETX> respectively, every <DLE> byte in the <data bytes> of a packet is preceded by an extra

<DLE> stuffing byte. These extra <DLE> bytes must be added (stuffed) before sending a packet and removed (unstuffed) after receiving the packet.

Note – A simple <DLE> <ETX> sequence does not necessarily signify the end of the packet, as these can be bytes in the middle of a data string. The end of a packet is <ETX> preceded by an odd number of <DLE> bytes.

Subpackets

Several packets support multiple functions which are processed using subpackets. Subpackets are treated as and behave like separate packets (see Figure 1-2).

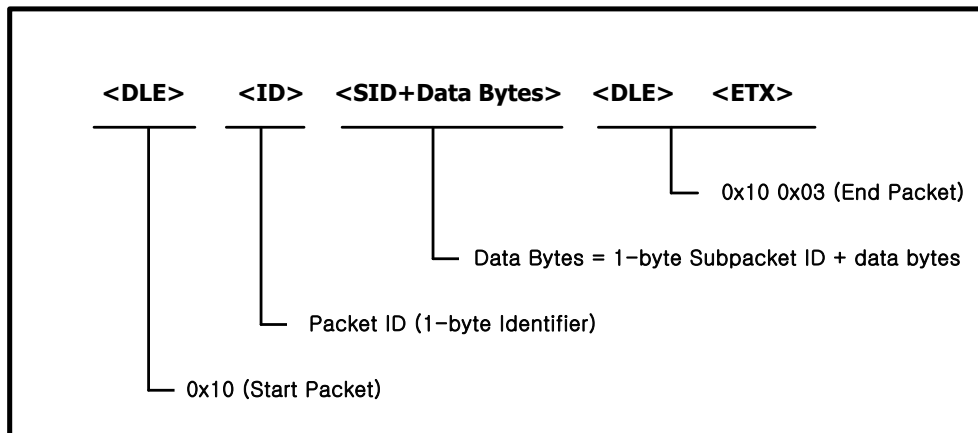

Figure 1-2 TSIP SubPacket Structure

To identify these subpackets, a 1-byte hexadecimal Subpacket ID (SID) is included as the first byte of data. Hexadecimal notation is used to identify the subpackets associated with a packet.

Data Types

Multiple-byte data types follow the ANSI / IEEE Standard and the IEEE-754 Standard for binary Floating-Point Arithmetic. These values are sent most-significant byte first and results in the switching the order of the bytes as they are normally stored. Only the fractional part of the mantissa for real numbers, Single and Double, is reported because the leading bit on the mantissa is always 1. TSIP supports the following data types:

Data Type	Description
UINT8	An 8-bit unsigned integer (0 to 255) -
SINT8	An 8-bit signed integer (-128 to 127)
INT16	An 16-bit unsigned integer (0 to 65,535)
SINT16	An 16-bit signed integer (-32,768 to 32,767)
UINT32	An 32-bit unsigned integer (0 to 4,294,967,295)
SINT32	An 32-bit signed integer (-2,147,483,648 to 2,147,483,647)

SINGLE	Single-precision float (4 bytes) (1.2×10^{-38} to 3.4×10^{38})
DOUBLE	Double-precision float (8 bytes) (2.2×10^{-308} to 1.8×10^{308})

Configuration Parameters

The following tables list the factory default settings for all ICM configuration parameters. Also listed are the packets IDs used to set, request and report these parameters.

GNSS Configuration

Parameter	Factory Default	Set	Request	Report
Receiver mode	Over-determined Clock Mode	0xBB	0xBB	0xBB
Sensitivity	Indoor (maximum sensitivity)			
Constellation	All available			
Anti-jamming	Enabled			
Elevation mask	10°			
Signal level mask	0.0 C/No (sets minimum level)			

Packet I/O Control

Parameter	Factory Default	Set	Request	Report
Packet broadcast mask		0x8E-A5	0x8E-A5	0x8E-A5
Mask0	0x05			
Mask1	0x00			
Packet 0x35 I/O Options		0x35	0x35	0x35
Position	0x12			
Velocity	0x02			
Timing	0x00			
Auxiliary	0x08			

Serial Port Configuration

Parameter	Factory Default	Set	Request	Report
Input baud rate	115200 bps	0xBC	0xBC	0xBC
Output baud rate	115200 bps			
Data bits	8 bits			
Parity	Odd			
Stop bits	1 bit			
Input / Output Protocol	TSIP (Trimble Standard Interface Protocol)			

Timing Outputs

Parameter	Factory Default	Set	Request	Report
PPS enable	1 (Enabled)	0x8E-4A	0x8E-4A	0x8F-4A
PPS sense	1 (Rising Edge)			
PPS offset	0.0 seconds			
PPS output qualifier	2 (Always on)	0x8E-4E	0x8E-4E	0x8F-4E
UTC/GPS Date/Time	0 (GPS)	0x8E-A2	0x8E-A2	0x8F-A2
UTC/GPS PPS alignment	0 (GPS)	0x8E-A2	0x8E-A2	0x8F-A2

Automatic Output Packets

The following table lists the packets that can be automatically sent by the ICM/RES to the user and under what conditions these packets will be sent.

Broadcast Packet ID	Description	Masking Packet ID	Request Packet ID	When Sent
0x42	Position XYZ(ECEF), single precision	0x35 and 0x8E-A5 (bit 6)	0x37	When a position fix is computed
0x43	Velocity XYZ, single precision	0x35 and 0x8E-A5 (bit 6)	0x37	When a position fix is computed
0x47	Signal Levels	0x8E-A5 (bit 6)	0x27	Once per second
0x4A	Position LLA, single precision	0x35 and 0x8E-A5 (bit 6)	0x37	When a position fix is computed
0x56	Velocity ENU, single precision	0x35 and 0x8E-A5 (bit 6)	0x37	When a position fix is computed
0x5A	Raw Measurements	0x35 and 0x8E-A5 (bit 6)	0x3A	When new measurements are available
0x6C	Satellite list, DOPS, mode	0x8E-A5 (bit 6)	0x24	Once per second
0x83	Position XYZ(ECEF), double precision	0x35 and 0x8E-A5 (bit 6)	0x37	When a position fix is computed
0x84	Position LLA, double precision	Position LLA, single precision	0x37	When a position fix is computed
0x8F-AB	Primary timing packet	0x8E-A5 (bit 0)	0x8E-AB	Once per second
0x8F-AC	Secondary timing packet	0x8E-A5 (bit 2)	0x8E-AC	Once per second

Packets Output at Reset

The following packets are automatically sent by the ICM/RES to the user after a Reset event, which can be triggered either by a hardware signal on the Reset pin or by a software command.

Byte	Item	Type	Value	Description
0	Packet ID	UINT8	0x45	
1	Application	UNIT8		Major version number of application
2		UNIT8		Minor version number of application
3		UNIT8		Month
4		UNIT8		Day
5		UNIT8		Year number minus 2000
6	GPS Core	UNIT8		Major revision number of GPS core
7		UNIT8		Minor revision number of GPS core
8		UNIT8		Month
9		UNIT8		Day
10		UNIT8		Year number minus 2000

Input Packets Supported

The following table lists the packets that can be sent the ICM/RES by the user.

Input ID	Packet Description	Output ID
0x1C	Firmware/Hardware version	0x1C
0x1E	Initiate cold, warm or factory reset	0x45 (after reset)
0x1F	Request software version	0x45
0x21	Current GPS time	0x41
0x24	Request GPS satellite selection	0x6C
0x26	Receiver health	0x46, 0x4B
0x27	Request signal levels	0x47
0x2E	Set GPS Time	0x4E
0x31	Set accurate position (XYZ ECEF)	-
0x32	Set accurate position (Lat, Long, Alt)	-
0x35	Set/request I/O options	0x55
0x37	Request status and value of last position and velocity fixes	0x57 (and other enabled packets)
0x38	Load/request satellite system data	0x58
0x39	Satellite enable/disable and health heed/ignore	0x59
0x3A	Request last raw measurement	0x5A
0x3C	Request current satellite tracking status	0x5D
0x7A	NMEA interval and message mask command	0x7B
0xBB	Set/request receiver configuration	0xBB
0xBC	Set/request serial port configuration	0xBB
0x8E-02	UTC information	0x8F-02
0x8E-26	Save configuration	-
0x8E-41	Request manufacturing parameters	0x8F-41
0x8E-42	Request production parameters	0x8F-42
0x8E-4A	Set/request PPS characteristics	0x8F-4A
0x8E-4E	Set/request PPS output options	0x8F-4E
0x8E-A0	Set/request DAC value	0x8F-A0
0x8E-A2	Set/request UTC/GPS timing	0x8F-A2
0x8E-A3	Issue oscillator disciplining command	0x8F-A3
0x8E-A5	Set/request packet broadcast mask	0x8F-A5
0x8E-A6	self-survey commands	0x8F-A6
0x8E-A9	self-survey parameters	0x8F-A9
0x8E-A8	Set/request oscillator disciplining parameters	0x8F-A8
0x8E-AB	Request primary timing packet	0x8F-AB

0x8E-AC	Request supplemental timing packet	0x8F-AC
---------	------------------------------------	---------

Output Packets Supported

The following table lists the packets that can be sent to the user by the ICM.

Output ID	Packet Description	Input ID
0x13	Invalid packet	Any
0x1C	Firmware/Hardware version	0x1C
0x2E	Request GPS Time	Auto
0x32	Request Unit Position	Auto
0x38	Request SV System data	Auto
0x41	GPS time	0x21
0x42	Single-precision XYZ position	0x37, auto
0x43	Velocity fix (XYZ ECEF)	0x37, auto
0x45	Software version information	0x1E, 0x1F
0x46	Health of receiver	0x26
0x47	Signal level for all satellites	0x27, auto
0x4A	Single-precision LLA position	0x37, auto
0x4B	Machine code/status	0x26
0x4E	Response to Set GPS Time	0x2E
0x55	I/O options	0x35
0x56	Velocity fix (ENU)	0x37, auto
0x57	Information about last computed fix	0x37
0x58	GPS system data/acknowledge	0x38
0x59	Satellite enable/disable and health heed/ignore	0x39
0x5A	Raw measurement data	0x3A
0x5D	Satellite tracking status	0x3C
0x6C	Satellite selection list	0x24, auto
0x7B	NMEA interval and message mask response	0x7A
0x83	Double-precision XYZ	0x37, auto
0x84	Double-precision LLA	0x37, auto
0xBB	Receiver configuration	0xBB
0xBC	Serial port configuration	0xBC
0x8F-02	UTC information	0x8E-02
0x8F-41	Stored manufacturing operating parameters	0x8E-41
0x8F-42	Stored production parameters	0x8E-42
0x8F-4A	PPS characteristics	0x8E-4A
0x8F-4E	PPS output options	0x8E-4E
0x8F-A0	DAC value	0x8E-A0

Output ID	Packet Description	Input ID
0x8F-A2	UTC/GPS timing	0x8E-A2
0x8F-A3	Oscillator disciplining command	0x8E-A3
0x8F-A5	Packet broadcast mask	0x8E-A5
0x8F-A6	self-survey commands	0x8E-A6
0x8F-A8	Oscillator disciplining parameters	0x8E-A8
0x8F-A9	self-survey parameters	0x8E-A9
0x8F-AB	Primary timing packet	0x8E-AB, auto
0x8F-AC	Supplemental timing packet	0x8E-AC, auto

Packet Descriptions

Report packet 0x13: Unparsable packet

This packet is sent in response to a received packet that was unparsable. A packet is unparsable if the packet ID is not recognized or if the length or content of the packet is not correct for the packet ID.

Byte	Item	Type	Value	Description
0	Packet ID	UINT8	0x13	
1-N	Data	UINT8		Packet data bytes of unparsable packet

Command packet 0x1C-01: Firmware Version

The command packet 0x1C: 01 may be issued to obtain the firmware version. The product name is ICM360 (or RES360). The packet format is defined in the following table:

Byte	Item	Type	Value	Description
0	Packet ID	UINT8	0x1C	Packet ID 0x1C
1	Subpacket ID	UINT8	0x01	Sub-code 0x01 for software component version information request

Report packet 0x1C-81: Firmware component version information

Byte	Item	Type	Value	Description
0	Packet ID	UINT8	0x1C	Packet ID 0x1C
1	Sub-code	UINT8	0x81	Sub-code 0x81 for software component version information report
2	Reserved	UINT8	Any	Reserved
3	Major version	UINT8	Any	Firmware major version
4	Minor version	UINT8	Any	Firmware minor version
5	Build number	UINT8	Any	Firmware build number
6	Month	UINT8	1-12	Firmware build month
7	Day	UINT8	1-31	Firmware build day
8...9	Year	INT16	Any	Firmware build year
10	Length of first module name	UINT8	Any	The length of the product name (L1)
11... (10+L1)	Product name	UINT8	String	Product name in ASCII

Command packet 0x1C-03: Hardware component version information

The command packet 0x1C-03 may be issued to obtain the hardware component version information. The report packet is of variable length, depending on the length of the hardware ID. The serial number, build date fields, and the hardware ID are programmed into the ICM SMT 360 at production.

The hardware code is 3026 (0xBD2)

The hardware ID is “ICM SMT 360”

The hardware information for RES SMT 360 is:

The hardware code is 3023 (0xBCF)

The hardware ID is “RES SMT 360”

The RES SMT 360 (17x22 mm):

The hardware code is 3031 (0xBD7)

The hardware ID is “RES360 17x22”

Byte	Item	Type	Value	Description
0	Packet ID	UINT8	0x1C	
1	Subpacket ID	UINT8	0x03	SubPacket ID 0x03 for hardware component version information request.

Report packet 0x1C-83: Hardware component version information

Byte	Item	Type	Value	Description
0	Packet ID	UINT8	0x1C	
1	Subpacket ID	UINT8	0x83	SubPacket ID 0x83 for hardware component version information report.
2-5	Serial Number	UINT32	Any	Board serial number
6	Build day	UINT8	1-31	Day if the board’s build date
7	Build month	UINT8	1-12	Month of the board’s build date
8-9	Build year	UINT16	Any	Year of the board’s build date
10	Build hour	UINT8	0-23	Hour of the board’s build date
11-12	Hardware code	UINT16	0xBD2	Hardware code associated with the hardware ID
13	Length of hardware ID	UINT8	Any	The length of the hardware ID (L)
14(13+L)	Hardware ID	UINT8	String	Hardware ID string in ASCII ICM SMT 360

Command packet 0x1E: Initiate Cold, Warm, or Factory Reset

This packet commands ICM/RES to perform either a cold reset, warm reset or a factory reset. A cold reset will clear the GPS data (almanac, ephemeris, etc.) stored in RAM and is equivalent to a power cycle. A factory reset will additionally restore the factory defaults of all configuration parameters stored in flash memory. A warm reset clears ephemeris and oscillator uncertainty but retains the last position, time and almanac. This packet contains one data byte.

The data format is shown below.

Byte	Item	Type	Value	Description
0	Packet ID	UINT8	0x1E	
1	Reset	UINT8	0x4B 0x0E 0x46	Cold reset Warm reset Factory reset

Note - The factory reset command will delete the stored position and cause a self-survey to restart.

Command packet 0x1F: Request Software Version

This packet requests information about the version of software in ICM/RES. This packet contains no data. ICM/RES returns packet 0x45.

Command Packet 0x21: Current Time Request

This packet requests current GNSS time. This packet contains no data. The GNSS receiver returns packet 0x41.

Command packet 0x24: Request GNSS satellite Selection

This packet requests a list of satellites used for the current position/time fix. This packet contains no data. ICM/RES returns packet 0x6C.

Command Packet 0x26: Health Request

This packet requests health and status information from the GNSS receiver. This packet contains no data. The GNSS receiver returns packets 0x46 and 0x4B.

Command packet 0x27: Request Signal Levels

This packet requests signal levels for all satellites currently being tracked. This packet contains no data. ICM/RES returns packet 0x47.

Command packet 0x2B: Set Approximate Initial Position

This packet is used for A-GPS (GPS only) to set and approximate initial WGS-84 position (Latitude, Longitude, and Altitude coordinates) for the receiver. This packet is useful when a

receiver is moved more than 1000Km from the location of the last position fix. This packet causes an immediate search for the visible SVs starting at the approximate initial position and widens the search to all SVs if the receiver cannot acquire enough SVs to generate a position. The receiver can initialize without any data from you, but it takes more time to generate a position.

This packet does not perform a software reset and is ignored when the receiver is already generating position.

Command Packet 0x2B Data Format (Double Precision)

Byte	Item	Type	Value/Unit	Description
0	Packet ID	UINT8	0x2B	
1-8	Latitude	DOUBLE	Radians	+ for north, - for south
9-16	Longitude	DOUBLE	Radians	+ for east, - for west
17-24	Altitude	DOUBLE	Meters	
25-28	Horizontal Uncertainty	SINGLE	meters	Default:30K Range: 0 ~ 3000Km
29-32	Vertical Uncertainty	SINGLE	meters	Default:500 Range: 0 ~ 500m

Command Packet 0x2B Data Format (Single Precision)

Byte	Item	Type	Value/Unit	Description
0	Packet ID	UINT8	0x2B	
1-4	Latitude	SINGLE	Radians	+ for north, - for south
5-8	Longitude	SINGLE	Radians	+ for east, - for west
9-12	Altitude	SINGLE	Meters	
13-16	Horizontal Uncertainty	SINGLE	meters	Default: 30000
17-20	Vertical Uncertainty	SINGLE	meters	Default: 500

Command packet 0x2E: Set GPS Time

This packet is used for A-GPS (GPS only). This packet sets the approximate GPS time of week and the week number in receiver memory, and the receiver responds by sending Report Packet 0x4E. The GPS week number reference is Week #0 starting January 6, 1980. The seconds count being at midnight each Sunday morning.

Byte	Item	Type	Value	Description
0	Packet ID	UINT8	0x2E	
1-4	GPS time	SINGLE	seconds	GPS time of week
5-6	GPS week	INTEGER	weeks	GPS week number

Command packet 0x2E-00: Request GPS Time (ICM/RES→Server only)

This packet requests GPS time to server if aiding data request mode is 1.

Byte	Item	Type	Value	Description
0	Packet ID	UINT8	0x2E	
1	Subpacket ID	UINT8	0x00	

Command packet 0x30: Set UTC Date and Time for future roll over date

This packet changes the Base week, to extend out the last valid WNRO number which would normally be based on the firmware build date.

Byte	Item	Type	Description
0	Packet ID	U8	30
1-2	Year	U16	Four Digits of the year
3	UTC:Month	U8	1-12
4	UTC:Day of Month	U8	1-31
5	UTC:Hour	U8	0-23
6	UTC:Min	U8	0-59
7	UTC:Sec	U8	0-59

NOTE: Do not use a date earlier than the current firmware date.

Command packet 0x31: Accurate Initial Position (XYZ Cartesian ECEF)

This packet provides an accurate initial position to the GPS receiver in XYZ coordinates. Either the single precision or the double precision version of this packet may be used, however, we recommend using the double precision version for greatest accuracy. ICM/RES uses this position for performing time-only fixes. If a survey is in progress when this command is sent, the survey is aborted and this position data is used immediately. ICM/RES will automatically switch to the over-determined timing mode when this command is issued.

Command Packet 0x31 Data Format (Single Precision)

Byte	Item	Type	Value/Unit	Description
0	Packet ID	UINT8	0x31	
1-4	X-axis	SINGLE	Meters	
5-8	Y-axis	SINGLE	Meters	
9-12	Z-axis	SINGLE	Meters	

Command Packet 0x31 Data Format (Double Precision)

Byte	Item	Type	Value/Unit	Description
0	Packet ID	UINT8	0x31	
1-8	X-axis	DOUBLE	Meters	
9-16	Y-axis	DOUBLE	Meters	
17-24	Z-axis	DOUBLE	Meters	

Command packet 0x32: Accurate Initial Position (Latitude, Longitude, Altitude)

This packet provides an accurate initial position to the GNSS receiver in latitude, longitude, and altitude coordinates. Either the single precision or the double precision version of this packet may be used, however, we recommend using the double precision version for greatest accuracy. The GPS receiver uses this position for performing time-only fixes. If a survey is in progress when this command is issued, the survey is aborted, and this position data is used immediately. The coordinates entered must be in the WGS-84 datum. ICM/RES will automatically switch to the over-determined timing mode when this command is issued.

Command Packet 0x32 Data Format (Single Precision)

Byte	Item	Type	Value/Unit	Description
0	Packet ID	UINT8	0x32	
1-4	Latitude	SINGLE	Radians	+ for north, - for south
5-8	Longitude	SINGLE	Radians	+ for east, - for west
9-12	Altitude	SINGLE	Meters	

Command Packet 0x32 Data Format (Double Precision)

Byte	Item	Type	Value/Unit	Description
0	Packet ID	UINT8	0x32	
1-8	Latitude	DOUBLE	Radians	+ for north, - for south
9-16	Longitude	DOUBLE	Radians	+ for east, - for west
17-24	Altitude	DOUBLE	Meters	

Command packet 0x32-00: Request GPS Position (ICM/RES →Server only)

This packet requests GPS position to server if aiding data request mode is 1.

Byte	Item	Type	Value	Description
0	Packet ID	UINT8	0x32	
1	Subpacket ID	UINT8	0x00	

Command packet 0x35: Set or Request I/O Options

This packet requests the current I/O option states and allows the I/O option states to be set as desired. To request the option states without changing them, the user sends this packet with no data bytes. To change any option states, the user includes 4 data bytes with the values. The I/O options, their default states, and the byte values for all possible states are shown below.

These options can be set into non-volatile memory (flash ROM) with the 0x8E-26 command. The GNSS receiver returns packet 0x55. These abbreviations apply to the following table:

- ALT: Altitude
- ECEF: Earth-Centered, Earth-Fixed
- XYZ: Cartesian coordinates
- LLA: Latitude, Longitude, Altitude
- HAE: Height Above Ellipsoid
- WGS-84: Earth model(ellipsoid)
- MSL: Mean Sea Level
- UTC: Universal coordinated Time

Byte	Data Type	Bit	Value	Meaning	Associated Packet
0	Packet ID		0x35		
1	Position	0	0	ECEF off	0x42 or 0x83
			1	ECEF on	
		1	0	LLA off	0x4A or 0x84
			1	LLA on	
		2	0	HAE (datum)	0x4A or 0x84
			1	MSL geoid (Note 1)	
3	0	Reserved			
4		0	0	Single-precision position	0x42/4A
			1	Double-precision position	0x83/84
		5-7	0	Reserved	
2	Velocity	0	0	ECEF off	0x43
			1	ECEF on	
		1	0	ENU off	0x56
	1	ENU on			
2-7	0	Reserved			
3	Timing	0	0	Reserved.	0x42, 0x43, 0x4A
			1	Now use 0x8E-A2	0x83, 0x84, 0x56
4	Auxiliary	0	0	Packet 5A off	0x5A
			1	Packet 5A on	

		1	0	Reserved	
		2	0	Reserved	
		3	0	Reserved	0x5A, 0x5D, 0x47
			1	Output dB-Hz	
		4-7	0	Reserved	

Note – When using the MSL altitude output, the current datum must be set to WGS-84

Command packet 0x37: Request Status and Values of Last Position

This packet requests information regarding the last position fix (normally used when the GPS receiver is not automatically outputting fixes.) The GPS receiver returns the position/velocity auto packets specified in the 0x35 message as well as message 0x57. This packet contains no data.

Command packet 0x38: Request Satellite System Data

This packet requests current GPS (only) satellite data.

Byte	Item	Type	Value/Unit	Description
0	Packet ID	UINT8	0x38	
1	Operation	UINT8	Flag	Must be always "1"
2	Type of data	UINT8	2 3 4 5 6	Almanac Health page, t_oa, WN_oa Ionosphere UTC Ephemeris
3	Sat PRN #	UINT8		Selects an individual satellite or all satellites 0: Data is not satellite specific 1-32: Data is requested for a specific satellite PRN (pseudorandom number) FF (ICM uses only): Data is requested for almanac or ephemeris of all satellites.

Command packet 0x38: Upload Satellite System Data

This packet is used for A-GPS (GPS only). Command packet 0x38 uploads GPS data (almanac, ephemeris, etc.) to GNSS receiver (ICM/RES SMT 360). The receiver acknowledges a download operation by sending the requested data in report packet 0x58.

The table and section numbers referred to in the "Meaning" column reference the ICD-GPS-200.

Byte	Item	Type	Value/Unit	Description
0	Packet ID	UINT8	0x38	
1	Operation	UINT8	2	Uploads satellite data into receiver if the receiver supports satellite data uploads
2	Type of data	UINT8	2 3 4 5 6	Almanac Health page, t_oa, WN_oa Ionosphere UTC Ephemeris
3	Sat PRN #	UINT8	0 1-32	Data is not satellite specific Data is requested for a specific satellite PRN (pseudorandom number)
4	Length	UNINT8		Number of data bytes to load
5 to (n+4)	Data			Data to be loaded Type 2: Almanac (see Table 1) Type 3: Health page, t_oa, WN_oa (see

Byte	Item	Type	Value/Unit	Description
				Table 2) Type 4: Ionosphere (see Table 3) Type 5: UTC (see Table 4) Type 6: Ephemeris (see Table 5)

Table 1. Data Type 2: Almanac

Byte	Item	Type	Meaning
5	t_oa_raw	UINT8	Refer to ICD-GPS-200, Sec 20.3.3.5.1.2
6	SV_HEALTH	UNIT8	Refer to ICD-GPS-200, Sec 20.3.3.5.1.2
7-10	e	Single	Refer to ICD-GPS-200, Sec 20.3.3.5.1.2
11-14	t_oa	Single	Refer to ICD-GPS-200, Sec 20.3.3.5.1.2
15-18	i_o	Single	Refer to ICD-GPS-200, Sec 20.3.3.5.1.2
19-22	OMEGADOT	Single	Refer to ICD-GPS-200, Sec 20.3.3.5.1.2
23-26	sqrt_A	Single	Refer to ICD-GPS-200, Sec 20.3.3.5.1.2
27-30	OMEGA_0	Single	Refer to ICD-GPS-200, Sec 20.3.3.5.1.2
31-34	OMEGA	Single	Refer to ICD-GPS-200, Sec 20.3.3.5.1.2
35-38	M_0	Single	Refer to ICD-GPS-200, Sec 20.3.3.5.1.2
39-42	a_f0	Single	Refer to ICD-GPS-200, Sec 20.3.3.5.1.2
43-46	a_f1	Single	Refer to ICD-GPS-200, Sec 20.3.3.5.1.2
47-50	Axis	Single	Refer to ICD-GPS-200, Sec 20.3.3.5.1.2
51-54	n	Single	Refer to ICD-GPS-200, Sec 20.3.3.5.1.2
55-58	OMEGA_n	Single	Refer to ICD-GPS-200, Sec 20.3.3.5.1.2
59-62	ODOT_n	Single	Refer to ICD-GPS-200, Sec 20.3.3.5.1.2
63-66	t_zc	Single	Refer to ICD-GPS-200, Sec 20.3.3.5.1.2
67-68	Week number	UINT16	Refer to ICD-GPS-200, Sec 20.3.3.5.1.2
69-70	WN_oa	UINT16	Refer to ICD-GPS-200, Sec 20.3.3.5.1.2

Note –All angles are in radians

Table 2. Data Type 3: Almanac Health

Byte	Item	Type	Meaning
5	Week number for health	UNIT8	Refer to ICD-GPS-200, Sec 20.3.3.5.1.3
6-37	SV_health	UNIT8 (32Bytes)	Refer to ICD-GPS-200, Sec 20.3.3.5.1
38	t_oa for health	UINT8	Refer to ICD-GPS-200, Sec 20.3.3.5.1
39	Current t_oa	UINT8	Units = seconds/4096
40-41	Current week #	UINT16	

Table 3. Data Type 4: Ionosphere

Byte	Item	Type	Meaning
5-12			Not used
13-16	Alpha_0	Single	Refer to ICD-GPS-200, Sec 20.3.3.5.1.9
17-20	Alpha_1	Single	Refer to ICD-GPS-200, Sec 20.3.3.5.1.9
21-24	Alpha_2	Single	Refer to ICD-GPS-200, Sec 20.3.3.5.1.9
25-28	Alpha_3	Single	Refer to ICD-GPS-200, Sec 20.3.3.5.1.9
29-32	Beta_0	Single	Refer to ICD-GPS-200, Sec 20.3.3.5.1.9
33-36	Beta_1	Single	Refer to ICD-GPS-200, Sec 20.3.3.5.1.9
37-40	Beta_2	Single	Refer to ICD-GPS-200, Sec 20.3.3.5.1.9
41-44	Beta_3	Single	Refer to ICD-GPS-200, Sec 20.3.3.5.1.9

Table 4. Data Type 5: UTC

Byte	Item	Type	Meaning
5-17			Not used
18-25	A_0	Double	Refer to ICD-GPS-200, Sec 20.3.3.5.1.8
26-29	A_1	Single	Refer to ICD-GPS-200, Sec 20.3.3.5.1.8
30-31	Delta_t_LS	SINT16	Refer to ICD-GPS-200, Sec 20.3.3.5.1.8
32-35	t_ot	Single	Refer to ICD-GPS-200, Sec 20.3.3.5.1.8
36-37	WN_t	UINT16	Refer to ICD-GPS-200, Sec 20.3.3.5.1.8
38-39	WN_LSF	UINT16	Refer to ICD-GPS-200, Sec 20.3.3.5.1.8
40-41	DN	UINT16	Refer to ICD-GPS-200, Sec 20.3.3.5.1.8
42-43	Delta_t_LSF	SINT16	Refer to ICD-GPS-200, Sec 20.3.3.5.1.8

Table 5. Data Type 6 : Ephemeris

Byte	Item	Type	Meaning
5	SV_number	UINT8	SV PRN number
6-9	t_ephem	Single	Time of collection
10-11	week number	UINT16	Refer to ICD-GPS-200, Sec 20.3.3.3, Table 20-l
12	CodeL2	UINT8	Refer to ICD-GPS-200, Sec 20.3.3.3, Table 20-l
13	L2Pdata	UINT8	Refer to ICD-GPS-200, Sec 20.3.3.3, Table 20-l
14	SVacc_raw	UNIT8	Refer to ICD-GPS-200, Sec 20.3.3.3, Table 20-l
15	SV_health	UINT8	Refer to ICD-GPS-200, Sec 20.3.3.3, Table 20-l
16-17	IODC	UINT16	Refer to ICD-GPS-200, Sec 20.3.3.3, Table 20-l
18-21	t_GD	Single	Refer to ICD-GPS-200, Sec 20.3.3.3, Table 20-l
22-25	t_oc	Single	Refer to ICD-GPS-200, Sec 20.3.3.3, Table 20-l
26-29	a_f2	Single	Refer to ICD-GPS-200, Sec 20.3.3.3, Table 20-l

Byte	Item	Type	Meaning
30-33	a_f1	Single	Refer to ICD-GPS-200, Sec 20.3.3.3, Table 20-l
34-37	a_f0	Single	Refer to ICD-GPS-200, Sec 20.3.3.3, Table 20-l
38-41	SVacc	Single	Refer to ICD-GPS-200, Sec 20.3.3.3, Table 20-l
42	IODE	UINT8	Refer to ICD-GPS-200, Sec 20.3.3.4
43	fit_interval	UINT8	Refer to ICD-GPS-200, Sec 20.3.3.4
44-47	C_rs	Single	Refer to ICD-GPS-200, Sec 20.3.3.4
48-51	Dalta_n	Single	Refer to ICD-GPS-200, Sec 20.3.3.4
52-59	M_0	Double	Refer to ICD-GPS-200, Sec 20.3.3.4
60-63	C_uc	Single	Refer to ICD-GPS-200, Sec 20.3.3.4
64-71	e	Double	Refer to ICD-GPS-200, Sec 20.3.3.4
72-75	C_us	Single	Refer to ICD-GPS-200, Sec 20.3.3.4
76-83	aqrt_A	Double	Refer to ICD-GPS-200, Sec 20.3.3.4
84-87	t_oe	Single	Refer to ICD-GPS-200, Sec 20.3.3.4
88-91	C_ic	Single	Refer to ICD-GPS-200, Sec 20.3.3.4
92-99	OMEGA_0	Double	Refer to ICD-GPS-200, Sec 20.3.3.4
100-103	C_is	Single	Refer to ICD-GPS-200, Sec 20.3.3.4
104-111	i_0	Double	Refer to ICD-GPS-200, Sec 20.3.3.4
112-115	C_rc	Single	Refer to ICD-GPS-200, Sec 20.3.3.4
116-123	Omega	Double	Refer to ICD-GPS-200, Sec 20.3.3.4
124-127	OMEGADOT	Single	Refer to ICD-GPS-200, Sec 20.3.3.4
128-131	IDOT	Single	Refer to ICD-GPS-200, Sec 20.3.3.4
132-139	Axis	Double	= (sqrt_A) ²
140-147	n	Double	Derived from delta_n
148-155	r1me2	Double	= sqrt(1.0-e ²)
156-163	OMEGA_n	Double	Derived from OMEGA_0, OMEGADOT
164-171	ODOT_n	Double	Derived from OMEGADOT

Note –All angles are in radians

Command Packet 0x39: Satellite Attribute Database Command

Normally, the GNSS receiver selects only healthy satellites (based on transmitted values in the ephemeris and almanac) that satisfy all mask values for use in the position solution. This packet allows you to override the internal logic and force the receiver to either unconditionally disable a particular satellite or to ignore a bad health flag. The GNSS receiver returns packet 0x59 for operation modes 3 and 6 only.

Byte	Item	Type	Value	Description
0	Operation	BYTE	1	Enable for selection (default)
			2	Disable for selection
			3	Request enable or disable status on byte 1 selection
			4	Heed health on satellite
			5	Ignore health on satellite
			6	Request heed or ignore health on byte 1 selection
1	SV Type	BYTE	0	All SVs
			1	GPS
			2	GLONASS
			3	BeiDou
			4	Galileo
			5	QZSS
2	SVID	BYTE	If byte 1 value:	
			0 then 0	All SVs
			1 then 1-32	GPS
			2 then 65-96	GLONASS
			3 then 201-237	BeiDou
			4 then 97-133	Galileo
			5 then 193-195	QZSS
			6 then 33-54	SBAS

NOTE: Send a WARM start command (0x1E 0x0E) after setting new values.

Command packet 0x3A: Request Last Raw Measurement

This packet requests the most recent raw measurement data for one specified satellite. The GNSS receiver returns packet 0x5A if data is available.

Byte	Item	Type	Value	Description
0	Packet ID	UINT8	0x3A	
1	Satellite PRN Convert values to Hexadecimal	UINT8	0	All SV in current tracking set
			1-32	GPS
			65-96	GLONASS
			97-133	Galileo
			183,192,193,200	QZSS
201-237	BeiDou			

Command packet 0x3C: Request Satellite Tracking Status

This packet requests the current satellite tracking status. The GPS receiver returns packet 0x5D if data is available

Byte	Item	Type	Value	Description
0	Packet ID	UINT8	0x3C	

1	Satellite PRN Convert values to Hexadecimal	UINT8	0 1-32 65-96 97-133 183,192,193,200 201-237	All SV in current tracking set GPS GLONASS Galileo QZSS BeiDou
---	---	-------	--	---

Command packet 0x7A: NMEA Interval and Message Mask Command

The NMEA message determines whether or not a given NMEA message will be output. If the bit for a message is set, the message will be sent every “interval” second. Use the values shown below to determine the NEMA interval and message mask. Response packet is 0x7B.

Byte	Bit	Item	Type	Value	Description
0		Packet ID	UINT8	0x7A	
1		Subpacket ID	UINT8	0x00	
2		Interval	UINT8	1-255	Fix interval in seconds
3-6		Bit Mask Values (See below)			

Bit Mask is the hexadecimal numbers that are OR'ed together to produce the combined output mask.

Message		Bit Mask
GGA	GPS fix data	0x00000001
GLL	Position fix, time of position fix, and status	0x00000002
VTG	Course over ground and Ground speed	0x00000004
GSV	Satellites in View	0x00000008
GSA	GPS DOP and Active Satellites	0x00000010
ZDA	Time and Date	0x00000020
RMC	Recommended Minimum Specific GPS Data	0x00000080
GST	GPS Pseudo range Noise statistics	0x00000400
PTNLAG001	Text Transmission	N/A
DTM	Datum Reference	
	Poll Message	

Report Packet 0x41: GPS Time Report

Legacy packet, use 0x8F-AB or 0x8F-AC instead.

This packet provides the current GNSS time of week and the week number for constellation selected in 0x8E-A2. The GNSS receiver sends this packet in response to packet 0x21.

Byte	Item	Type	Units
0-3	GNSS time of week	Single	Seconds
4-5	GNSS week number	Integer	Weeks
6-9	UTC offset	Single	seconds

Report packet 0x42: Single-precision Position Fix

This packet provides current GPS position fix in XYZ ECEF coordinates. If the I/O “position” option is set to “XYZ ECEF” and the I/O “Precision-of-Position output” is set to single-precision, then the GPS receiver sends this packet each time a fix is computed or in response to packet 0x37. The data format is shown below. The time-of-fix is in GPS or UTC as selected by the I/O “timing” option in packet 0x35. Packet 0x83 provides a double-precision version of this information.

Byte	Item	Type	Value/Unit	Description
0	Packet ID	UINT8	0x42	
1-4	X	SINGLE	meters	
5-8	Y	SINGLE	meters	
9-12	Z	SINGLE	meters	
13-16	time-of-fix	SINGLE	seconds	

Report packet 0x43: Velocity Fix, XYZ ECEF

This packet provides current GPS velocity fix in XYZ ECEF coordinates. If the I/O “velocity” option (packet 0x35) is set to “XYZ ECEF”, then the GPS receiver sends this packet each time a fix is computed or in response to packet 0x37. The data format is shown below. The time-of-fix is in GPS or UTC as selected by the I/O “timing” option.

Byte	Item	Type	Value/Unit	Description
0	Packet ID	UINT8	0x43	
1-4	X velocity	SINGLE	meters/second	
5-8	Y velocity	SINGLE	meters/second	
9-12	Z velocity	SINGLE	meters/second	
13-16	bias rate	SINGLE	meters/second	
17-20	time-of-fix	SINGLE	seconds	

Report packet 0x45: Software Version Information

This packet provides information about the version of firmware running on the ICM/RES. The GNSS receiver sends this packet after power-on in response to one of the 0x1E reset commands.

Byte	Item	Type	Value	Description
0	Packet ID	UINT8	0x45	
1	Application Layer of the firmware	UNIT8		Major version number of application
2		UNIT8		Minor version number of application
3		UNIT8		Month

Byte	Item	Type	Value	Description
4		UNIT8		Day
5		UNIT8		Year number minus 2000
6	GPS Core Layer of the firmware	UNIT8		Major revision number of GPS core
7		UNIT8		Minor revision number of GPS core
8		UNIT8		Month
9		UNIT8		Day
10		UNIT8		Year number minus 2000

Report Packet 0x46: Health of Receiver Report

Legacy packet, use 0x8F-AB or 0x8F-AC instead.

This packet provides information about the satellite tracking status and the operational health of the receiver. The receiver sends this packet after power-on or software-initiated resets, in response to packet 0x26, during an update cycle, when a new satellite selection is attempted, and when the receiver detects a change in its health. Packet 0x4B is always sent with this packet. The data format is shown below:

Byte	Item	Type	Value	Meaning
0	Status code	Byte	00 hex	Doing position fixes
			01 hex	Do not have GPS time yet
			08 hex	No usable satellites
			09 hex	Only 1 usable satellite
			0A hex	Only 2 usable satellites
			0B hex	Only 3 usable satellites
			0C hex	The chosen satellite is unusable
			BB hex	Have GPS time fix (OD mode)
1	Error codes	Byte		See Report Packet 0x46

The error codes in Byte 1 of packet 0x46 are encoded into individual bits within the byte. The bit positions and their meanings are shown below:

Error code bit position	Meaning if bit value = 1
0 (LSB)	Unused, always returned as '1'
1	Unused
2	Unused
3	Unused
4	Antenna feed line fault (open or short)
5	Antenna is shorted
6	Unused
7 (MSB)	unused

Report packet 0x47: Signal Level for All Satellites Tracked

This packet provides received signal levels for all satellites currently being tracked or on which tracking is being attempted (i.e., above the elevation mask and healthy according to the almanac). The receiver sends this packet in response to packet 0x27 or automatically as listed in the Automatic Output Packets section (0x8E-A5, bit 6). The data format is shown below. Up to 12 satellite number/signal level pairs may be sent as indicated by the count field. Signal level is normally positive. If it is zero then that satellite has not yet been acquired. If it is negative then that satellite is not currently in lock. The absolute value of signal level field is the last known signal level if that satellite.

Byte	Item	Type	Value/Unit	Description
0	Packet ID	UINT8	0x47	
1	Count	UINT8		
2	Satellite number1	UINT8		
3-6	Signal level1	SINGLE		
7	Satellite number2	UINT8		
8-11	Signal level2	SINGLE		
(etc.)	(etc.)	(etc.)		

Note –The signal level provided in this packet is a linear measure of the signal strength after correlation or de-spreading. Units are dB-Hz as controlled by packet 0x35.

Report packet 0x4A: Single Precision LLA position Fix

This packet provides current GPS position fix in LLA coordinates. If the I/O position option is set to “LLA” and the I/O precision of position output is set to single precision, then the receiver sends this packet each time a fix is computed. The data format is shown below.

Byte	Item	Type	Value/Unit	Description
0	Packet ID	UINT8	0x4A	
1-4	Latitude	SINGLE	radians	+ for north, - for south
5-8	Longitude	SINGLE	radians	+ for east, - for west
9-12	Altitude	SINGLE	meters	
13-16	Clock bias	SINGLE	meters	
17-20	Time-of-fix	SINGLE	seconds	

The LLA conversion is done using WGS-84 datum. Altitude is referred to the datum or the MSL Geoid, depending on which I/O LLA altitude option is selected with packet 0x35. The time of fix is in GPS time or UTC, depending on which I/O timing option is selected.

CAUTION –When converting from radians to degrees, significant and ready visible errors will be introduced by use of an insufficiently precise approximation for the constant π (pi). The value of a constant π as specified in ICD-GPS-200 is 3.1415926535898.

CAUTION – The MSL option is only valid with the WGS-84 datum. When using other datums, only the HAE option is valid.

Report Packet 0x4B: Machine/Code ID and Additional Status Report

Legacy packet, use 0x8F-AB or 0x8F-AC instead.

The receiver transmits this packet in response to packet 0x26 and following a change in state. This packet identifies the receiver and may present error messages. Packet 0x46 is always sent with this packet. The machine ID can be used by equipment communicating with the receiver to determine the type of receiver to which the equipment is connected. Then the interpretation and use of packets can be adjusted accordingly.

Byte	Item	Type	Meaning
0	Machine ID	BYTE	0x01 Reports Machine ID
1	Status 1	BYTE	See below for the Status 1 codes
2	Status 2	BYTE	Super packets are supported

The status codes are encoded into individual bits within the bytes:

Status 1 Bit Position	Meaning if bit value = 1
0 (LSB)	Not used
1	Not used
2	Not used
3	The Almanac stored in the receiver is not complete & current
4-7	Not used

Report packet 0x4E: GPS Time Command Verification

This packet reports whether or not the receiver accepted the time given in a Set GPS Time Packet (0x2E). This packet contains one data byte.

Byte	Item	Type	Value	Description
0	Packet ID	UINT8	0x4E	
1	Result	UINT8	0x4E	The receiver did not accept the time in Command Packet 0x2E, but the receiver did receive the time from a satellite and is using that time. The receiver ignores the time setting in Command Packet 0x2E.

Value	Meaning
ASCII "Y"	The receiver accepts the time entered via Packet 2E. The receiver has not yet received the time from a satellite.
ASCII "N"	The receiver does not accept the time entered via Packet 2E. The receiver has received the time from a satellite and uses that time. The receiver disregards the time in Packet 0x2E

Report packet 0x55: I/O Options

This packet provides the current I/O option states in response to packet 0x35 request. The data format is the same as for packet 0x35.

Report packet 0x56: Velocity Fix, East-North-Up (ENU)

If ENU coordinates have been selected for the I/O "velocity" option, the receiver sends this packet each time that a fix is computed or in response to packet 0x37. The data format for this packet is shown below.

Byte	Item	Type	Value/Unit	Description
0	Packet ID	UINT8	0x56	
1-4	East velocity	SINGLE	m/s	+ for east, - for west
5-8	North velocity	SINGLE	m/s	+ for north, - for south
9-12	Up velocity	SINGLE	m/s	+ for up, - for down
13-16	Clock bias rate	SINGLE	m/s	
17-20	Time-of-fix	SINGLE	seconds	

Note –The time-of-fix is in GPS or UTC time as selected by the I/O "timing" option.

Report packet 0x57: Information about Last Computed Fix

This packet provides information concerning the time and origin of the previous position fix. The receiver sends this packet, among others, in response to packet 0x37.

Byte	Item	Type	Value/Unit	Description
0	Packet ID	UINT8	0x57	
1	Source of info	UINT8	0 1	Old fix New fix
2	Fix mode	UINT8	0 1 2 3 4 5	No previous fix Time only 1-SV2D Not used 2D 3D Over-determined clock

Byte	Item	Type	Value/Unit	Description
			6	Not used
3-6	Time of last fix	SINGLE	seconds	
7-8	Week of last fix	UINT16	weeks	

Report packet 0x58: GPS System Data from Receiver

This packet provides GPS data (almanac, ephemeris, etc.). The receiver sends this packet in response to packet 0x38. The data format is shown below. The table and section numbers referred to in the “Meaning” column reference the ICD-GPS-200.

Data format is the same as command packet 0x38: Upload Satellite System Data.

Byte	Item	Type	Value/Unit	Description
0	Packet ID	UINT8	0x58	
1	Operation	UINT8	2 3	Data out no data on SV
2	Type of data	UINT8	2 3 4 5 6	Almanac Health page, t_oa, WN_oa Ionosphere UTC Ephemeris
3	Sat PRN #	UINT8	0 1-32	Data is not satellite specific Data is requested for a specific satellite PRN (pseudorandom number)
4	Length	UNINT8		Number of data bytes to load
5 to (n+4)	Data			Data to be loaded Type 2: Almanac (see Table 1) Type 3: Health page, t_oa, WN_oa (see Table 2) Type 4: Ionosphere (see Table 3) Type 5: UTC (see Table 4) Type 6: Ephemeris (see Table 5)

Report Packet 0x59: Satellite Attributes Database Report

This packet is returned in response to packet 0x39 if operation mode 3 or 6 is used with packet 0x39.

Normally the GNSS receiver selects only healthy satellites (based on transmitted values in the ephemeris and almanac) that satisfy all mask values, for use in the position solution.

Packet 0x59 indicates whether or not each satellite is allowed to be selected for use in the position solution, and whether each satellite’s health is to be heeded or ignored.

Note – When viewing the satellite disabled list, the satellites are not numbered but are in numerical order. The disabled satellites are signified by a 1 and enabled satellites are signified by a 0.

Byte	Item	Type	Value	Description
0	Operation	BYTE	3	Request enable or disable status on byte 1 selection
			6	Request heed or ignore health on byte 1 selection
1	SV Type	BYTE	1 then 1-32	GPS
			2 then 65-96	GLONASS
			3 then 201-237	BeiDou
			4 then 97-133	Galileo
			5 then 193-195	QZSS
			6 then 33-54	SBAS
2~38	SVID	BYTE	1 byte per SV (depends on byte 0 value)	
			0	Enable SV selection or head SV health
			1	Disable SV selection or ignore SV health

Report packet 0x5A: Raw Data Measurement Data

This packet provides raw GPS measurement data. This packet is sent in response to packet 0x3A or automatically if enabled with packet 0x35.

Byte	Item	Type	Value/Unit	Description
0	Packet ID	UINT8	0x5A	
1	SV PRN #	SINGLE		
2-5	Sample length	SINGLE	milliseconds	
6-9	Signal level	SINGLE	dB-Hz	
10-13	Code phase	SINGLE	1/16 th chip	
14-17	Doppler	SINGLE	Hertz @ L1	
18-25	Time of measurement	DOUBLE	seconds	

Note –The sample length is the number of milliseconds over which the sample was averaged.

Note –The code phase value is the average delay over the sample interval of the received C/A code, and is measured with respect to the receiver’s millisecond timing reference.

Report packet 0x5D: GNSS Satellite Tracking Status

The receiver sends this packet in response to command packet 0x3C, when the unit is configured for multi-GNSS operation.

Byte	Bit	Item	Type	Value	Description
0		Packet ID	UINT8	0x5D	
1		SV PRN #	UINT8		See table in 0x3C description
2		Channel number	UINT8		Channel number minus 1
3		acquisition flag	UINT8	0 1 2	Never acquired Acquired Re-opened search
4		SV used in Position or Time calculation	UINT8	0 1	Not Used Used
5-8		signal level	SINGLE		dB-Hz
9-12		time of last measurement	SINGLE	seconds	GPS TOW
13-16		elevation angle	SINGLE	radians	
17-20		azimuth angle	SINGLE	radians	
21		old measurement flag	UINT8	0 >0	Flag not set Measurement old
22		integer msec flag	UINT8	0 1	Don’t know msec Known from subframe

Byte	Bit	Item	Type	Value	Description
				2	Verified by bit crossing
				3	verified by good fix
				4	Suspect msec error
23		bad data flag	UINT8	0	Flag not set
				1	Bad parity
				2	Bad ephemeris health
24		data collection flag	UINT8	0	Flag not set
				>0	Collection in progress
25		Used flags	Bit field	Bit 0	Satellite used in timing fix
				Bit 1	Satellite used in position fix
				Bit 2-7	reserved
26		SV Type	UINT8	0	GPS
				1	GLONASS
				2	BeiDou
				3	Galileo
				4	Reserved
				5	QZSS
				6	Reserved
				7	Reserved

Report packet 0x5F-01-0B: Reset Error Codes

The receiver automatically outputs this packet in response to a reset.

Byte	Item	Type	Value	Description
0	Packet ID	UINT8	0x5F	
1	Packet Sub-code	UINT8	0x01	
2	Function ID	UINT8	0x0B	
3 - 4	Reserved	UINT16	0x0000	
5 - 6	Error Code	UINT16		0x0B03: Receiver has detected millisecond error 0x0B04: Watchdog reset 0x0B05: CPU Overload 0x0B06: Receiver has detected ms error in more than 2 satellites for more than 15 seconds 0x0B0A: no communication with the GNSS system 0x0B0D: The receiver has not entered into active mode for more than 30 min (ICM 360 only) 0x0B0E: No PPS generated from GNSS system for 6 seconds
7 -25	Time of Error	U8x19	19-char ASCII	hh:mm:ss mm/dd/yyyy

Note – The TSIP report packet 0x5F-01-0B is for Trimble internal use. It is listed in the user guide for information only and backward compatibility.

Report packet 0x6C: Satellite Selection List

This packet provides a list of satellites used for position or time-only fixes by the GNSS receiver. The packet also provides the PDOP, HDOP, VDOP and TDOP of that set and provides the current mode (automatic or manual, 3-D or 2-D, over-determined clock, etc.) This packet has variable length equal to 17+nsvs where “nsvs” is the number of satellites used in the solution. If an SV is rejected for use by the T-RAIM algorithm then the SV PRN value will be negative. The GPS receiver sends this packet in response to packet 0x24 or automatically.

Byte	Bit	Item	Type	Value	Description
0		Packet ID	UINT8	0x6C	
1	0-2	fix dimension	bit field	001	1D clock fix
				011	2D fix
				100	3D fix
101				OD clock fix	
	3	fix mode	bit field	0 1	Auto Manual
	4-7	Reserved	bit field		Reserved
2-5		PDOP	SINGLE		
6-9		HDOP	SINGLE		
10-13		VDOP	SINGLE		
14-17		TDOP	SINGLE	0x01	TDOP is always reported = 1
18		# of SVs in fix	UINT8		Number of SVs to follow
19-n		SV PRN	UINT8	(1-224)	

Report Packet 0x7B: Set NMEA Message Output

This packet is sent in response to command packet 7A and has the same data format as packet 7A.

Report packet 0x83: Double Precision XYZ

This packet provides current GPS position fix in XYZ ECEF coordinates. If the I/O “position” option is set to “XYZ ECEF” and the I/O double position option is selected, the receiver sends this packet each time a fix is computed.

Byte	Item	Type	Value/Unit	Description
0	Packet ID	UINT8	0x83	

1-8	X	DOUBLE	meters	
9-16	Y	DOUBLE	meters	
17-24	Z	DOUBLE	meters	
25-32	clock bias	DOUBLE	meters	
33-36	time-of-fix	SINGLE	seconds	

Note –The time-of-fix is in GPS time or UTC, as selected by the I/O “timing” option. Packet 0x42 provides a single-precision version of this information.

Report packet 0x84: Double Precision LLA Position (Fix and Bias Information)

This packet provides current GPS position fix in LLA coordinates. If the I/O “position” option is set to “LLA” and the double position option is selected (see packet 0x35), the receiver sends this packet each time a fix is computed.

Byte	Item	Type	Value/Unit	Description
0	Packet ID	UINT8	0x84	
1-8	latitude	DOUBLE	radians	+ for north, - for south
9-16	longitude	DOUBLE	radians	+ for east, - for west
17-24	altitude	DOUBLE	meters	
15-32	clock bias	DOUBLE	meters	
33-36	time-of-fix	SINGLE	seconds	

Note –The time-of-fix is in GPS time or UTC time as selected by the I/O “timing” option.

Command packet 0xBB: Set Receiver Configuration

In query mode, packet 0xBB is sent with a single data byte and returns report packet 0xBB in the format shown below.

Byte	Item	Type	Value/Unit	Description
0	Packet ID	UINT8	0xBB	
1	Subpacket ID	UINT8	0x00	Query mode

TSIP packet 0xBB is used to set the GNSS receiver options. The table below lists the individual fields within the 0xBB packet.

Byte	Item	Type	Value/Unit	Description
0	Packet ID	UINT8	0xBB	
1	Subpacket ID	UINT8	0x00	Primary receiver configuration block
2	receiver mode	UINT8	0 1 3 4	Automatic (2D/3D) Single satellite (1 SV time) Horizontal (2D) Full position (3D)

Byte	Item	Type	Value/Unit	Description
			7	Over-determined clock
3	reserved	UINT8	0xFF	do not alter
4	reserved	UINT8	0xFF	do not alter
5	reserved	UINT8	0xFF	do not alter
6-9	Elevation mask	SINGLE	0- $\pi/2$	Lowest satellite elevation for fixes (radians), only when the receiver is operating in OD clock mode.
10-13	C/No mask	SINGLE	0-55	Minimum signal level for fixes, only when unit operating in OD mode
14-17	PDOP mask	SINGLE		Default = 6
18-21	PDOP switch	SINGLE		Unused, value ignored
22	reserved	UINT8	0xFF	do not alter
23	Anti-Jam Mode	UINT8	0 1	Disabled Enabled
24-27	reserved	UINT8	0xFF	do not alter
28	Constellation – see note	Bit	0 1 2 3 4 5 6 7	GPS GLONASS Reserved, unused BeiDou Galileo QZSS Ignored Ignored
29-40	reserved	UINT8	0xFF	do not alter

Note: Byte 28 is used for enabling/disabling use of a constellation. For GPS only mode 1st bit position is set to 1 (0001), for GLONASS only mode 2nd bit position is set to 1 (eg. 0010) and for GPS & GLONASS mode both 1st and 2nd bits are set to 1 (0011).

Note: The only limitation on satellite selection is that both GLONASS and BeiDou cannot be enabled at the same time. If they are both enabled then the unit will disable BeiDou and use GLONASS only

CAUTION – The operation of ICM/RES can be affected adversely if incorrect data is entered in the fields associated with packet 0xBB.

Note –When sending packet 0xBB, fields that are specified as “do not alter” or if you do not want to alter a specified field, send a value of 0xFF for UINT8 types and a value of -1.0 for floating point types. ICM will ignore these values.

Command packet 0xBC: Set Port Configuration

TSIP packet 0xBC is used to set and query the port characteristics. In query mode, packet 0xBC is sent with a single data byte and returns report packet 0xBC.

Note –The input and output baud rates must be the same.

Command packet 0xBC Data Format (Query Mode)

Byte	Item	Type	Value/Unit	Description
0	Packet ID	UINT8	0xBC	
1	Port Number	UINT8	0 1 0xFF	Port 1 (Default) Port 2 Current port

The table below lists the individual fields within the packet 0xBC when used in the set mode and when read in the query mode.

Command and Report packet 0xBC Field Data Format

Byte	Item	Type	Value/Unit	Description
0	Packet ID	UINT8	0xBC	
1	Port to Change	UINT8	0 1 0xFF	Port 1 (Default) Port 2 Current port
2	Input Baud Rate	UINT8	6 7 8 9 10 11	4800 baud 9600 baud 19200 baud 38400 baud 57600 baud 115200 baud
3	Output Baud Rate	UINT8	As above	As above
4	# Data bits	UINT8	2 3	7 bits 8 bits
5	Parity	UINT8	0 1 2	None Odd Even
6	# Stop bits	UINT8	0 1	1 bit 2 bits
7	Reserved	UINT8	0	
8	Input Protocols	UINT8	0 2 4	None TSIP NMEA
9	Output Protocols	UNIN8	0	None

Byte	Item	Type	Value/Unit	Description
			2 4	TSIP NMEA
10	Reserved	UINT8	0	

Command packet 0x8E-02 Request UTC Information

This packet allows the user to query UTC Information. The module responds to a query with packet 0x8F-02

Byte	Item	Type	Value	Description
0	Packet ID	UINT8	8E	
1	Subpaket ID	UINT8	02	
2	Type of data	UINT8	01	GPS
			02	BeiDou
			03	Galileo

Command packet 0x8E-26: Request Configuration to Flash ROM

This command packet causes the current configuration settings to be written to the flash ROM. This packet contains only a single byte: the subpacket ID.

Command packet 0x8E-41: Request Manufacturing Parameters

This packet is used to request the manufacturing parameters stored in non-volatile memory. Send this packet with no data (don't forget the subpacket ID) to request packet 0x8F-41.

Command packet 0x8E-42: Stored Production Parameters

This packet is used to request the production parameters stored in non-volatile memory. Send this packet with no data (don't forget the subpacket ID) to request packet 0x8F-42.

Command packet 0x8E-4A: Set PPS Characteristics

This packet allows the user to query (by sending the packet with no data bytes) or set ICM PPS characteristics. ICM responds to a query or set command with packet 0x8F-4A.

Byte	Item	Type	Value/Unit	Description
0	Packet ID	UINT8	0x8E	
1	Subpacket ID	UINT8	0x4A	
2	PPS driver switch	UINT8	0 1	off on (default)
3	Reserved	UINT8		
4	PPS polarity	UINT8	0 1	positive (default) negative
5-12	PPS offset of cable	DOUBLE	seconds	

Byte	Item	Type	Value/Unit	Description
	delay (see note)			
13-16	Bias uncertainty threshold	SINGLE	150.0 meters	

Note –Negative offset values advance the PPS, and are normally used to compensate for cable delay. Useful values for the PPS offset are between ± 50 ms.

Command packet 0x8E-4B: Set external PPS offset (ICM SMT 360 only)

Use command packet 0x8E-4B to apply an offset to the secondary PPS input. ICM responds with packet 0x8F-4B.

Byte	Item	Type	Value	Description
0	Packet ID	UINT8	0x8E	
1	Subpacket ID	UINT8	0x4B	
2	Desired reference	S32	0 (default)	External PPS offset in ns Valid range +/-50ms

Command packet 0x8E-4E : Set PPS Output Option

This command packet sets the PPS driver switch to one of the values listed in Table of command packet 0x8E-A2. The current driver switch value can be requested by sending the packet with no data bytes except the subpacket ID. Driver switch values 3 and 4 only make sense in over-determined Timing mode. In any position fix mode the effective choice are always on or during fixes which you get if you set the driver switch to 3 or 4.

Byte	Item	Type	Value	Description
0	Packet ID	UINT8	0x8E	
1	Subpacket ID	UINT8	0x4E	Subpacket ID
2	PPS Driver Switch	UINT8	Bit Field	One or more aiding data types Bits 2-0 : 1PPS/PP2S qualifier 010: 1PPS/PP2S is always on (default) 011: 1PPS/PP2S is on when at least 1 SV is usable 100: 1PPS/PP2S is on when at least 3SV are usable Bits 5-3: Not used , set to 0 Bit 6: Not used , set to 0 Bit 7: 1PPS/PP2S selection 0 : Generate 1PPS output (default) 1: Generate PP2S output

Command packet 0x8E-A2: UTC/GPS Timing

This command packet sets the UTC/GPS timing mode (time and data fields) in packet 0x8F-AB, and the temporal location of ICM output PPS. Send packet 0x8E-A2 with no data to request the current settings. ICM replies with response packet 0x8F-A2.

Byte	Item	Type	Bit	Value	Description
0	Packet ID	UINT8		0x8E	
1	Subpacket ID	UINT8		0xA2	Subpacket ID
2	Time Flag	Bit Field	0	0	GPS time (Default)
				1	UTC or GNSS time
			1	0	GPS PPS (Default)
				1	UTC or GNSS PPS
			2	0	Reserved
			3	0	Reserved
			4-5	0	UTC (USNO) time
				1	GLONASS time
				2	BeiDou time
				3	Galileo time
			6-7	0	UTC (USNO) PPS
				1	GLONASS PPS
				2	BeiDou PPS
				3	Galileo PPS

Command packet 0x8E-A3: Issue Oscillator Disciplining Command (ICM SMT 360 only)

Use command packet 0x8E-A3 to issue an oscillator disciplining command. ICM responds with Packet 0x8F-A3 in the same format as packet 0x8E-A3.

Byte	Item	Type	Value	Description
0	Packet ID	UINT8	0x8E	
1	Subpacket ID	UINT8	0xA3	
2	Disciplining Command	UINT8	0	Place PPS on time (jam sync)
			1	Transition to recovery state
			2	Transition to manual holdover
			3	Transition from manual holdover
			4	Disable oscillator disciplining
			5	Enable oscillator disciplining

Command packet 0x8E-A5: Packet Broadcast Mask

Use command packet 0x8E-A5 to set the packet broadcast masks or to request the current mask settings. ICM/RES replied to request with response packet 0x8F-A5. The broadcast mask is bitwise encoded to allow the use to turn on and off the broadcast of certain packets. For each bit in the mask that is used, the coding is as follows:

0: Turn off broadcast of this packet

1: Turn on broadcast of this packet

Byte	Item	Type	Bit	Value	Description
0	Packet ID	UINT8		0x8E	
1	Subpacket ID	UINT8		0xA5	Subpacket ID
2-3	Mask 0	bit field	0		0x8F-AB, Primary Timing Information
			1		Reserved
			2		0x8F-AC, Supplemental Timing Information
			3		Reserved
			4		Reserved
			5		Reserved
			6		Automatic Output Packets
4-5	Mask 1	bit field			Reserved

Command Packet 0x8E-A6: Self-Survey Command

Use command packet 8E-A6 to issue a self-survey command, to save the current position in flash or to delete the position saved in flash. The GNSS receiver returns report packet 0x8F-A6, which indicates the result of the requested operation.

Byte	Item	Type	Value	Description
0	Subcode	UINT8	0xA6	
1	Self-survey command	UINT8	0	Restart self-survey
			1	Save position to Flash
			2	Delete position from Flash

Command Packet 0x8E-A7: Set desired reference (ICM SMT 360 only)

Use command packet 8E-A7 to set the source of the ICM SMT 360 reference. The GNSS receiver returns report packet 0x8F-A7, which indicates the result of the requested operation.

Byte	Item	Type	Value/Unit	Description
0	Packet ID	U8	0x8E	
1	Subpacket ID	U8	0xA7	
2	Desired reference	U8	0	GNSS (default)
			1	External PPS

Note – The user needs to make sure the module is locked to a GNSS constellation before using the 0x8E-A7 command to configure the external reference option.

Command packet 0x8E-A8: Set or Request Disciplining Parameters (ICM SMT 360 only)

Note – This packet allows the user to change key disciplining parameters in the ICM.

This packet is usually intended to be used only when instructed by the factory. Incorrect use of this packet will most likely cause ICM timing outputs to be degraded severely. However, the “Type 2” (Recovery Mode) parameters are intended to be set by the user to suit the application. Send this packet with the type field only to request the current setting. ICM replies to sets and requests with the packet 0x8F-A8.

Type	Data field	Description
0	Type	A “0” in this field indicates that the packet contains loop dynamics information.
	Time Constant	This field carries the time constant of the disciplining control loop
	Damping Factor	This field carries the damping of the disciplining control loop.
1	Type	A “1” in this field indicates that the packet contains 10MHz oscillator parameters.
	OCXO Constant	This field carries the OCXO constant into Hz/Volt.
	OCXO Min. Control Voltage	This field carries the minimum (most negative) control voltage that can be applied to the 10MHz oscillator’s control voltage input.
	OCXO Max. Control Voltage	This field carries the maximum (most positive) control voltage that can be applied to the 10MHz oscillator’s control voltage input.
2	Type	A “2” in this field indicates that the packet contains Recovery Mode parameters. These parameters allow the user to control the recovery process. During Recovery, ICM will remove any PPS offset accumulated during period of Holdover by either shifting the PPS into alignment or by shifting the frequency of the 10MHz oscillator by a specified amount until the PPS has slewed back into alignment or by using both methods. The following tow parameters control these methods: - If a fast recovery is desired, allow jam syncs to be used - If it is important to maintain 10 million clock cycles per PPS pulse,

Type	Data field	Description
		then disable jam syncs and set the maximum frequency offset to a tolerable value.
	Jam Sync Threshold	This field carries the jam sync threshold in nanoseconds used during Recovery mode. While in Recovery Mode, if the PPS offset is above this threshold, ICM will automatically perform a jam sync to shift the PPS into alignment with GPS. The minimum allowed value is 50 ns. Setting a value less than or equal to 0ns will disable automatic jam syncs during Recovery (though the user can still issue a jam sync command with packet 0x8E-A3).
	Max. Frequency Offset	This field carries the maximum allowable frequency offset in ppb (parts per billion or 1E-09) of the 10MHz oscillator during Recovery Mode. While in Recovery Mode, ICM will remove any PPS offset accumulated during periods of Holdover by shifting the frequency of the oscillator by an amount up to the value specified. The minimum allowed value is 5ppb.
3	Type	A "3" in this field indicates that the packet contains the initial DAC voltage parameter.
	Initial DAC Voltage	At reset, the oscillator's frequency control voltage is set to this value.

Command Packet 0x8E-A8 Type 0 Data Format

Byte	Item	Type	Value	Description
0	Packet ID	UINT8	0x8E	
1	Subpacket ID	UINT8	0xA8	
2	Type	UINT8		0 = Loop dynamics
3-6	Time Constant	SINGLE		Seconds
7-10	Damping Factor	SINGLE		Dimensionless

Command Packet 0x8E-A8 Type 1 Data Format

Byte	Item	Type	Value	Description
0	Packet ID	UINT8	0x8E	
1	Subpacket ID	UINT8	0xA8	
2	Type	UINT8		1 = Oscillator parameters
3-6	Oscillator Gain Constant	SINGLE		Hz/Volt
7-10	Min. Control Voltage	SINGLE		Volts
11-14	Max. Control Voltage	SINGLE		Volts

Command Packet 0x8E-A8 Type 2 Data Format

Byte	Item	Type	Value	Description
0	Packet ID	UINT8	0x8E	
1	Subpacket ID	UINT8	0xA8	
2	Type	UINT8		2 = Recovery mode parameters
3-6	Jam sync threshold	SINGLE		nanosecond
7-10	Max. Frequency Offset	SINGLE		ppb

Command Packet 0x8E-A8 Type 3 Data Format

Byte	Item	Type	Value	Description
0	Packet ID	UINT8	0x8E	
1	Subpacket ID	UINT8	0xA8	
2	Type	UINT8		3 = Initial DAC voltage
3-6	Initial DAC Voltage	SINGLE		Volts

Command Packet 0x8E-A9: Self-Survey Parameters

Use command packet 8E-A9 to set the self-survey parameters or to request the current settings. The Resolution SMT 360 replies to requests with response packet 8F-A9.

Data fields

- Self-Survey Enable: Use this field to enabled or disabled the self-survey mechanism.
 - 0: Disable the self-survey mechanism
 - 1: Enable the self-survey mechanism
- Position Save Flag: Use this field to tell the self-survey mechanism to automatically save (or to not save) the self-surveyed position at the end of the self-survey procedure.
 - 0: Don't automatically save the surveyed position when the self-survey is complete
 - 1: Automatically save the surveyed position when the self-survey is complete.
- Self-Survey Length: Use this field to specify the number of position fixes that are to be averaged together to form the self-surveyed position used for clock-only fixes.
 - Limits: 1 to $(2^{32} - 1)$ fixes
- Uncertainty threshold. An index from 1 to 100. The smaller the number the higher degree of certainty of the self-survey fix will be used to fix the position of the unit for OD mode. Depending on the constellation and position of the satellites a small index number can lead to survey times of many hours as the unit may only qualify a small rate of fixes to complete the designated survey length (default 2000).

Byte	Item	Type	Value	Description
0	Subcode	UINT8	0xA9	

1	Self-Survey Enable	UINT8	0	Disabled
			1	Enabled
2	Position Save Flag	UINT8	0	Don't save position
			1	Save self-surveyed position at the end of the survey
3-6	Self-Survey Length	UINT32	see above	Number of fixes
7-10	Horizontal Uncertainty	Float	>0<=100	Horizontal position uncertainty. Default: 100
11-14	Vertical Uncertainty	Float	>0<=100	Vertical position uncertainty. Default: 100

Command packet 0x8E-AB: Request Primary Timing Packet

Use this command packet to request the Primary Timing packet 0x8F-AB. By default, the ICM/RES automatically sends packet 0x8F-AB once per second so it is not necessary to request it. To receive 0x8F-AB information by request only, use packet 0x8E-A5 to disable the automatic output.

Byte	Item	Type	Value	Description
0	Packet ID	UINT8	0x8E	
1	Subpacket ID	UINT8	0xAB	
2	Request Type	UINT8	0	Send 0x8F-AB immediately
			1	Send 0x8F-AB on-time next second
			2	Send 0x8F-AB and 0x8F-AC on-time next second

The Request Type item determines how the ICM/RES will reply to this command:

Type	Description
0	The most current primary timing values will be sent in packet 0x8F-AB immediately
1	The response is not sent immediately. Instead packet 0x8F-AB is sent after the next PPS output. This is the same time that the packet would be automatically sent if enabled
2	Same as type 1 except that both 0x8F-AB and 0x8F-AC are sent after the next PPS output.

Command packet 0x8E-AC: Request Supplemental Timing Packet

Use command packet 0x8E-AC to request the Supplemental Timing packet 0x8F-AC. By default, the ICM/RES automatically sends packet 0x8F-AC once per second so it is not necessary to request it. To receive 0x8F-AC information by request only, use packet 0x8E-A5 to disable the automatic output.

Byte	Item	Type	Value	Description
0	Packet ID	UINT8	0x8E	
1	Subpacket ID	UINT8	0xAC	

2	Request Type	UINT8	0	Send 0x8F-AC immediately
			1	Send 0x8F-AC on-time next second
			2	Send 0x8F-AB and 0x8F-AC on-time next second

The Request Type item determines how the ICM will reply to this command:

Type	Description
0	The most current primary timing values will be sent in packet 0x8F-AC immediately
1	The response is not sent immediately. Instead packet 0x8F-AC is sent after the next PPS output. This is the same time that the packet would be automatically sent if enabled
2	Same as type 1 except that both 0x8F-AB and 0x8F-AC are sent after the next PPS output.

Report packet 0x8F-02: UTC Information

This packet is sent in response to 0x8E-02.

Byte	Item	Type	Value	GPS	BeiDou	Galileo
0	Packet ID	UINT8	8F			
1	Subpacket ID	UINT8	02			
2	Constellation	UINT8		1	2	3
3-10	A_0	Double				
11-14	A_1	Single				
21-22	WN_t	UINT16			0	
23-24	WN_LSF	UINT16			0	
25-26	DN	UINT16				
27-18	Delta_t_LSF	SINT16				

Report packet 0x8F-41: Stored Manufacturing Operating Parameters

This packet is sent in response to a command 0x8E-41.

Byte	Item	Type	Value/Unit	Description
0	Packet ID	UINT8	0x8F	
1	Subpacket ID	UINT8	0x41	
2-3	Reserved	UINT16		
4-7	Board serial #	UINT32		
8	Year of build	UINT8		
9	Month of build	UINT8		
10	Day of build	UINT8		
11	Hour of build	UINT8		
12-15	Reserved	SINGLE		
16-17	Reserved	UINT16		

Report packet 0x8F-42: Stored Production Parameters

This packet is sent in response to 0x8E-42.

Byte	Item	Type	Value/Unit	Description
0	Packet ID	UINT8	0x8F	
1	Subpacket ID	UINT8	0x42	
2	Reserved	UINT8		
3	Reserved	UINT8		
4-5	Reserved	UINT16		
6-9	Reserved	UINT32		
10-13	Reserved	UINT32		
14-15	Reserved	UINT16		
16-17	Reserved	UINT16		
18-19	Reserved	UINT16		

Report packet 0x8F-4A: Set PPS Characteristics

This is sent in response to a query by packet 0x8E-4A. See the corresponding command packet for information about the data format.

Report packet 0x8F-4B: Set external PPS offset (*ICM SMT 360 only*)

This is sent in response to command packet 0x8E-4B with the offset to the secondary PPS input.

Byte	Item	Type	Value	Description
0	Packet ID	UINT8	0x8F	
1	Subpacket ID	UINT8	0x4B	
2-5	PPS offset	S32	ns	Current external PPS offset in ns

Report packet 0x8F-4E: PPS Output

This report packet is output after the command packet 0x8E-4E has been executed. See the corresponding command packet for information about the data format.

Report packet 0x8F-A0: DAC Value (*ICM SMT 360 only*)

This packet is sent in response to packet 0x8E-A0.

Data Field	Description
DAC Value	The current numeric value of the DAC.
DAC Voltage	The current output voltage of the DAC in Volts
DAC Resolution	The number of bits used in the DAC

DAC Data Format	The format of the DAC value
Min. DAC Voltage	The minimum (most negative) voltage that the DAC can produce
Max. DAC Voltage	The maximum (most positive) voltage that the DAC can produce

Report Packet 0x8F-A0 Data Format

Byte	Item	Type	Value/Unit	Description
0	Packet ID	UINT8	0x8F	
1	Subpacket ID	UINT8	0xA0	
2-5	DAC Value	UINT32		Value
6-9	DAC Voltage	SINGLE		Volts
10	DAC Resolution	UINT8		Number of bits
11	DAC Data Format	UINT8	0 1	Offset binary 2's complement
12-15	Min. DAC Voltage	SINGLE		Volts
16-19	Max. DAC Voltage	SINGLE		Volts

Report packet 0x8F-A2: UTC/GPS Timing

This packet is sent in response to command packet 0x8E-A2. See the corresponding command packet for information about the data format.

Report packet 0x8F-A3: Oscillator Disciplining Command (*ICM SMT 360 only*)

This packet is sent in response to command packet 0x8E-A3. See the corresponding command packet for information about the data format.

Report packet 0x8F-A5: Packet Broadcast Mask

This packet is sent in response to 0x8E-A5 command and describes which packets are currently automatically broadcast. A '0' in a bit field turns off broadcast, and a '1' in a bit field enables broadcast. See the corresponding command packet for information about the data format.

Report Packet 0x8F-A6: Self-Survey Command

This packet is sent in response to command packet 0x8E-A6. The packet indicates the result of the requested self-survey operation.

Byte	Item	Type	Value	Description
0	Sub-code	UINT8	0xA6	Packet sub-code
1	Self-survey command	UINT8	0	Restart self-survey
			1	Save position to Flash memory
			2	Delete position from Flash memory
2	Status	UINT8	0	Requested command successful
			1	Requested command failed

Report Packet 0x8F-A7: Set desired reference (ICM SMT 360 only)

This packet is sent in response to 0x8E-A7 the source of the ICM SMT 360 reference. The GNSS receiver returns report packet 0x8F-A7, which indicates the result of the requested operation.

Byte	Item	Type	Value/Unit	Description
0	Packet ID	U8	0x8F	
1	Subpacket ID	U8	0xA7	
2	Desired reference	U8	0	GNSS (default)
			1	External PPS

Report packet 0x8F-A8: Oscillator Disciplining Parameters (ICM SMT 360 only)

This packet is sent in response to command packet 0x8E-A8. See the corresponding command packet for information about the data format.

Report Packet 0x8F-A9: Self-Survey Parameters

Packet 0x8F-A9 is sent in response to command packet 0x8E-A9 and describes the current self-survey parameters. See the corresponding command packet for information about the data format.

Report packet 0x8F-AB: Primary Timing Packet

This packet provides time information once per second. GPS week number, GPS time-of-week (TOW), UTC integer offset, time flags, data and time-of-delay (TOD) information is provided. This packet can be requested or enabled for automatic broadcast once per second. If enabled, this packet will be transmitted shortly after the PPS pulse to which it refers.

Byte	Item	Type	Value	Description																																									
0	Packet ID	UINT8	0x8F																																										
1	Subpacket ID	UINT8	0xAB																																										
2-5	Time of week	UINT32		GPS seconds of week or from 0x8E-A2 time selection																																									
6-7	Week Number	UINT16		GPS Week Number or from 0x8E-A2 time selection																																									
8-9	UTC Offset	SINT16		UTC Offset (seconds) from chosen constellation time reference. Always = 0 when GLONASS time is selected.																																									
10	Time Flag	Bit Field		<table border="1"> <thead> <tr> <th>Bit</th> <th>Value</th> <th>Description</th> </tr> </thead> <tbody> <tr> <td rowspan="2">0</td> <td>0</td> <td>GPS time (Default)</td> </tr> <tr> <td>1</td> <td>UTC or GNSS time</td> </tr> <tr> <td rowspan="2">1</td> <td>0</td> <td>GPS PPS (Default)</td> </tr> <tr> <td>1</td> <td>UTC or GNSS PPS</td> </tr> <tr> <td rowspan="2">2</td> <td>0</td> <td>Time is set</td> </tr> <tr> <td>1</td> <td>Time is not set</td> </tr> <tr> <td rowspan="2">3</td> <td>0</td> <td>Have UTC info</td> </tr> <tr> <td>1</td> <td>No UTC info</td> </tr> <tr> <td rowspan="4">4-5</td> <td>0</td> <td>UTC time</td> </tr> <tr> <td>1</td> <td>GLONASS time</td> </tr> <tr> <td>2</td> <td>BeiDou time</td> </tr> <tr> <td>3</td> <td>Galileo time</td> </tr> <tr> <td rowspan="4">6-7</td> <td>0</td> <td>UTC PPS</td> </tr> <tr> <td>1</td> <td>GLONASS PPS</td> </tr> <tr> <td>2</td> <td>BeiDou PPS</td> </tr> <tr> <td>3</td> <td>Galileo PPS</td> </tr> </tbody> </table>	Bit	Value	Description	0	0	GPS time (Default)	1	UTC or GNSS time	1	0	GPS PPS (Default)	1	UTC or GNSS PPS	2	0	Time is set	1	Time is not set	3	0	Have UTC info	1	No UTC info	4-5	0	UTC time	1	GLONASS time	2	BeiDou time	3	Galileo time	6-7	0	UTC PPS	1	GLONASS PPS	2	BeiDou PPS	3	Galileo PPS
				Bit	Value	Description																																							
				0	0	GPS time (Default)																																							
					1	UTC or GNSS time																																							
				1	0	GPS PPS (Default)																																							
					1	UTC or GNSS PPS																																							
				2	0	Time is set																																							
					1	Time is not set																																							
				3	0	Have UTC info																																							
					1	No UTC info																																							
				4-5	0	UTC time																																							
					1	GLONASS time																																							
					2	BeiDou time																																							
3	Galileo time																																												
6-7	0	UTC PPS																																											
	1	GLONASS PPS																																											
	2	BeiDou PPS																																											
	3	Galileo PPS																																											
11	Seconds	UINT8	0-59	Seconds																																									
12	Minutes	UINT8	0-59	Minutes																																									
13	Hours	UINT8	0-23	Hours																																									
14	Day of Month	UINT8	1-31	Day of Month																																									
15	Month	UINT8	1-12	Month of Year																																									
16-17	Year	UINT16		Four digits of Year																																									

Data Field	Description
Time of Week	This field represents the number of seconds since Sunday at 00:00:00 GPS,

Data Field	Description
	GLONASS and Galileo time for the current week. For BeiDou it is for the number of seconds since Monday at 00:00:00. Time of week is often abbreviated as TOW.
Week Number	This field represents the current GNSS week number.
UTC Offset	UTC (USNO) offset = GPS time - UTC (USNO) time. UTC (INRIM) offset = Galileo time - UTC (INRIM) time. UTC (NTSC) offset = BeiDou time - UTC (NTSC) time. UTC (SU) offset = 0
Timing Flags	This field is bitwise encoded to provide information about the timing outputs. Unused bits should be ignored. Bit 0: When 0, the date and time fields broadcast in packet 8F-AB (Primary Timing Message) are in the GPS time scale. When 1, these fields are in the UTC time scale and are adjusted for leap seconds. Bit 1: When 0, the PPS output is aligned to GPS. When 1, the PPS output is aligned to UTC. Bit 2: When 0, time has been set. When 1, time has not yet been set. Bit 3: When 0, UTC offset information has been received. When 1, UTC offset information is not yet known.
Date	The date is sent in day-month-year format.

Report packet 0x8F-AC: Supplemental Timing Packet

This packet provides supplemental timing information once per second. Information regarding position, unit status and health, and the operational state of the unit. This packet can be requested or enabled for automatic broadcast, when enabled, this packet is transmitted once per seconds shortly after packet 0x8F-AB.

Byte	Item	Type	Value	Description
0	Packet ID	UINT8	0x8F	
1	Subpacket ID	UINT8	0xAC	
2	Receiver Mode	UINT8	0 1 3 4 7	Automatic (2D/3D) Single Satellite (Time) Horizontal (2D) Full Position (3D) Over-determined Clock
3	Disciplining Mode (Available only in ICM SMT 360. Mark as Reserved in RES SMT 360)	UINT8	0 1 2 3 4 5	Normal (Locked to GPS) Power Up Auto Holdover Manual Holdover Recovery Not used

Byte	Item	Type	Value	Description
			6	Disciplining Disabled
4	Self-Survey Progress	UNIT8		0-100%
5-8	Holdover Duration	UINT32		Seconds (ICM SMT 360 only)
9-10	Critical Alarms	UINT16	Bit Field	Bit 4 : DAC at rail (ICM SMT 360 only)
11-12	Minor Alarms	UINT16	Bit Field	Bit 0 : DAC near rail (ICM SMT 360 only) Bit 1 : Antenna Open Bit 2 : Antenna shorted Bit 3 : Not tracking satellites Bit 4 : Not disciplining oscillator (ICM only) Bit 5 : Survey-in progress Bit 6 : No stored position Bit 7 : Leap second pending Bit 8 : In test mode Bit 9 : Position is questionable Bit 10 : Not used Bit 11 : Almanac not complete Bit 12 : PPS not generated
13	GNSS Decoding Status	UINT8	0x00 0x01 0x08 0x09 0x0A 0x0B 0x0C	Doing fixes Don't have GNSS time No usable satellites Only 1 usable sat Only 2 usable sats Only 3 usable sats The chosen sat is unusable
14	Disciplining Activity (Only available in ICM SMT 360)	UINT8	0x00 0x01 0x02 0x03 0x04 0x05 0x06 0x07 0x08 0x09	Phase Locking Oscillator warm-up Frequency locking Placing PPS Initializing loop filter Compensating OCXO (Holdover) Inactive Not used Recovery mode Calibration/control voltage
15	PPS indication (Available only in RES SMT 360 – Reserved for ICM SMT 360)	UINT8	0	PPS Good indication
			1	PPS Not Good indication
16	PPS reference	UINT8		0x00 = GNSS, 0x01 = External, 0xFF = None
17-20	PPS Offset	Single		ns

Byte	Item	Type	Value	Description
21-24	Clock Offset	Single		ppb
25-28	DAC Value	UINT32		ICM SMT 360 only
29-32	DAC Voltage	Single		Volts
33-36	Temperature	Single		Degrees C
37-44	Latitude	Double		Radians
45-52	Longitude	Double		Radians
53-60	Altitude	Double		Meters
61-64	Spare		0	Always 0
65-68	Spare			Future expansion

Data Field	Description
Receiver Mode	This field shows the fix mode that the GNSS receiver is currently configured for.
Self-Survey Progress	When a self-survey procedure is in progress, this field shows the progress of the survey as a percentage of fixes collected so far. The self-survey will be complete when the self-survey progress reaches 100%. This field only has meaning while a self-survey is in progress.
Holdover Duration	When in the Manual or Auto Holdover state, this field show the amount of time spent in holdover in seconds. When the unit is not in a holdover state, this field shows the amount of time the ICM spent the last time it was in a holdover state.
Critical Alarm	Bit 4 : When 1, indicates that the oscillator control voltage is at a rail. If this condition persists then the ICM can no longer bring the frequency of the oscillator into alignment with GNSS and is most likely in need of a new oscillator.
Minor Alarms	<p>This field is bitwise encoded with several minor alarm indicators. A minor alarm indicates a condition that the user should be alerted to, but does not indicate an immediate (or necessarily any) impairment of functionality. For each bit, a value of 0 means that the condition is not indicated. Bits not described below should be ignored.</p> <p>Bit 0: When 1, indicates that the oscillator control voltage is near a rail. If this condition persists, then the oscillator is within specific time of becoming un-tunable. (It depends on oscillator used for ICM)</p> <p>Bit 1: When 1, indicates that the antenna input connection is open. More precisely, this bit indicates that the antenna input is not drawing sufficient current.</p> <p>Bit 2: When 1, indicates that the antenna input is shorted. More precisely, this bit indicates that the antenna input is drawing too much current.</p> <p>Bit 3: When 1, indicates that no satellites are usable.</p> <p>Bit 4: When 1, indicates that the oscillator is not being disciplined to GNSS. Before the ICM can begin disciplining the oscillator, it must begin</p>

Data Field	Description
	<p>receiving information from the receiver.</p> <p>Bit 5: When 1, indicates that a self-survey procedure is in progress.</p> <p>Bit 6: When 1, indicates that there is no accurate position stored in Flash ROM.</p> <p>Bit 7: When 1, indicates that the GNSS system has alerted ICM that a leap second transition is pending.</p> <p>Bit 8: When 1, indicates that ICM is operating in one of its test modes.</p> <p>Bit 9: When 1, indicates that the accuracy of the position used for time only fixes is questionable.</p> <p>Bit 11: When 1, indicates that the Almanac is not current or complete.</p> <p>Bit 12: When 1, indicates the PPS was not generated this second. This could mean there wasn't enough usable satellites to generate an accurate PPS output.</p>
GNSS Decoding Status	This field indicates the decoding status of the GPS receiver.
Disciplining Activity	This field indicates the current activity of the disciplining mechanism.
PPS Indication	<p>The "PPS good" indicator is composed of:</p> <ol style="list-style-type: none"> 1. Unit has achieved a 'first fix' 2. Unit has resolved the millisecond ambiguity. This is done with a proprietary algorithm. 3. The unit has at least one satellite that is has passed all Trimble proprietary timing integrity checks (TRAIM). These include, but are not limited to: <ul style="list-style-type: none"> • Satellite is in the constellation list of allowed timing sources • Satellite millisecond ambiguity has been established • Satellite signal strength is above the user setting for signal strength • Satellite elevation is above the elevation mask • Satellite tracking filter has settled 4. PPS has been generated for at least 4 seconds after GNSS system restart
PPS Offset	This field carries the estimate of the offset of the PPS output relative to UTC or GPS as reported by the GPS receiver in nanoseconds. Positive values indicate that the ICM's PPS is coming out late relative to GPS or UTC.
Clock Offset	This field carries the estimate of the frequency offset of the SCLK output relative to UTC or GPS as reported by the GPS receiver in ppb. Positive values indicate that the ICM's clock is running slow relative to GPS or UTC.
DAC Value	This field shows the numeric value of the DAC used to produce the voltage that controls the frequency of the SCLK oscillator.
DAC Voltage	This field show the voltage output of the DAC.
Temperature	This field show the temperature (in Celsius) as reported by ICM's on-board temperature sensor.

Data Field	Description
Latitude	This field carries the latitude of the position being shown. The units are in radians and vary from $-\pi/2$ to $+\pi/2$. Negative values represent southern latitudes. Positive values represent northern latitudes.
Longitude	This field carries the longitude of the position being shown. The units are in radians and vary from $-\pi$ to $+\pi$. Negative values represent western longitudes. Positive values represent eastern longitudes.
Altitude	This field carries the altitude of the position being shown. The units are in meters (WGS-84.)

NMEA 0183 Protocol

In this chapter:

Introduction

NMEA 0183 communication interface

NMEA 0183 message structure

Field definitions

NMEA 0183 message options

NMEA 0183 message formats

Exception behavior

This appendix provides a brief overview of the NMEA 0183 protocol, and describes both the standard and optional messages offered by the ICM SMT 360.

Introduction

The National Marine Electronics Association (NMEA) protocol is an industry standard data protocol which was developed for the marine industry.

NMEA 0183 is a simple, yet comprehensive ASCII protocol which defines both the communication interface and the data format. The NMEA 0183 protocol was originally established to allow marine navigation equipment to share information. Since it is a well-established industry standard, NMEA 0183 has also gained popularity for use in applications other than marine electronics.

NMEA data is output in standard ASCII sentence formats. Message identifiers are used to signify what data is contained in each sentence. Data fields are separated by commas within the NMEA sentence. In the ICM/RES SMT 360™ multi-GNSS timing module, NMEA is a bi-directional protocol. Because NMEA 0183 does not specify input sentences, a set of Trimble-proprietary input messages is provided. See Appendix B, NMEA 0183 Protocol.

The ICM/RES SMT 360™ is available with firmware that supports a subset of the NMEA 0183 messages: GGA, GLL, GSA, GSV, RMC, VTC, and ZDA. For a nominal fee, Trimble can offer custom firmware with a different selection of messages to meet your application requirements.

The NMEA output messages selection and message output rate can be set using TSIP command packet 0x7A. The default setting is to output the GGA, GSA, GSV, VTG, and ZDA messages at a 1 second interval, when the receiver output protocol is configured to NMEA, using packet 0xBC.

If NMEA is to be permanent for the application, the protocol configuration (0xBC) and NMEA message output setting (0x7A) can be stored in the non-volatile memory (on-board flash) using TSIP command 0x8E-26.

NMEA 0183 communication interface

NMEA 0183 allows a single source (talker) to transmit serial data over a single twisted wire pair to one or more receivers (listeners). The table below lists the standard characteristics of the NMEA 0183 data transmissions.

Signal	NMEA Standard
Baud rate	115 kbps
Data bits	8
Parity	Odd (Disabled)
Stop bits	1

NMEA 0183 message structure

The NMEA 0183 protocol covers a broad array of navigation data. This broad array of information is separated into discrete messages which convey a specific set of information. The entire protocol encompasses over 50 messages, but only a sub-set of these messages apply to a GPS receiver like the ICM/RES SMT 360. The NMEA message structure is described below.

\$IDMSG,D1,D2,D3,D4,.....,Dn*CS[CR][LF]

Where:

\$	Signifies the start of a message
ID	The talker identification is a two letter mnemonic which describes the source of the navigation information. The GP identification signifies a GPS source while GL will signify a GLONASS source. In the event that the information in the sentence is agnostic the ID will be GP.
MSG	The message identification is a three letter mnemonic which describes the message content and the number and order of the data fields.
,	Commas serve as delimiters for the data fields.
Dn	Each message contains multiple data fields (Dn) which are delimited by commas.
*	The asterisk serves as a checksum delimiter.
CS	The checksum field contains two ASCII characters which indicate the hexadecimal value of the checksum.
[CR][LF]	The carriage return [CR] and line feed [LF] combination terminate the message.

NMEA 0183 messages vary in length, but each message is limited to 79 characters or less. This length limitation excludes the "\$" and the [CR][LF]. The data field block, including delimiters, is limited to 74 characters or less.

Field definitions

Many of the NMEA data fields are of variable length, and the user should always use the comma delineators to parse the NMEA message data field. The following table specifies the definitions of all field types in the NMEA messages supported by Trimble:

Type	Symbol	Definition
Status	A	Single character field: A=Yes, data valid, warning flag clear V=No, data invalid, warning flag set

Special Format Fields

Type	Symbol	Definition
Latitude	llll.lll	Fixed/variable length field: Degreesminutes.decimal-2 fixed digits of degrees, 2 fixed digits of minutes and a variable number of digits for decimal-fraction of minutes. Leading zeroes always included for degrees and minutes to maintain fixed length. The decimal point and associated decimal- fraction are optional if full resolution is not required.
Longitude	yyyyy.yyy	Fixed/Variable length field: Degreesminutes.decimal-3 fixed digits of degrees, 2 fixed digits of minutes and a variable number of digits for decimal-fraction of minutes. Leading zeroes always included for degrees and minutes to maintain fixed length. The decimal point and associated decimal- fraction are optional if full resolution is not required.
Time	hhmmss.ss	Fixed/Variable length field: hoursminutesseconds.decimal-2 fixed digits of minutes, 2 fixed digits of seconds and a variable number of digits for decimal-fraction of seconds. Leading zeroes always included for hours, minutes, and seconds to maintain fixed length. The decimal point and associated decimal-fraction are optional if full resolution is not required.
Defined		Some fields are specified to contain pre-defined constants, most often alpha characters. Such a field is indicated in this standard by the presence of one or more valid characters. Excluded from the list of allowable characters are the following that are used to indicated field types within this standard: "A", "a", "c", "hh", "hhmmss.ss", "llll.ll", "x", "yyyyy.yy"
Numeric Value Fields		
Variable	x.x	Variable length integer or floating numeric field. Optional leading and trailing zeros. The decimal point and associated decimal-fraction are optional if full resolution is not required (example: 73.10=73.1=073.1=73).
Fixed HEX	hh	Fixed length HEX numbers only, MSB on the left
Information Fields		
Fixed Alpha	aa	Fixed length field of upper-case or lower-case alpha characters.
Fixed Number	xx	Fixed length field of numeric characters

Note –

- Spaces are only be used in variable text fields.

- Units of measure fields are appropriate characters from the Symbol column unless a specified unit of measure is indicated.
- Fixed length field definitions show the actual number of characters. For example, a field defined to have a fixed length of 5 HEX characters is represented as hhhhh between delimiters in a sentence definition.

NMEA 0183 message options

The ICM/RES SMT 360™ can output any or all of the messages listed in the table below. In its default configuration (as shipped from the factory), the ICM/RES SMT 360™ outputs only TSIP messages. Typically, NMEA messages are output at a 1 second interval with the "GP" talker ID and checksums. These messages are output at all times during operation, with or without a fix. If a different set of messages has been selected (using Packet 0x7A), and this setting has been stored in flash memory (using Packet 0x8E-26), the default messages are permanently replaced until the receiver is returned to the factory default settings.

Note – The user can configure a custom mix of the messages listed in the table below. See Chapter 3, and TSIP command packets 0xBC, 0x7A, and 8E-26 in Appendix A for details on configuring NMEA output.

CAUTION – If too many messages are specified for output, you may need to increase the unit's baud rate.

Message	Description
GGA	GPS fix data
GLL	Geographic position Latitude/Longitude
GSA	GPS DOP and active satellites
GSV	GPS satellites in view
RMC	Recommended minimum specific GPS/Transit data
VTG	Track made good and ground speed
ZDA	Time and date

ICM/RES SMT 360™ multi-GNSS timing module proprietary NMEA messages

Message	Description
AH	Query or set almanac health.
AL	Query or set almanac data for a specific satellite.
AS	Query or set almanac status
BA	Query and response to antenna status
CR	Query or set GPS receiver configuration information.
EM	Set receiver into Monitor Mode. Set only

Message	Description
EP	Query or set ephemeris data for a specific satellite.
FS	Query or set GPS receiver acquisition sensitivity.
IO	Query or set ionosphere data.
KG	Set initial position and time info data for to aid navigation startup.
NM	Query or set NMEA automatic message output control.
PS	Query or set PPS configuration.
PT	Query or set serial port configuration.
RT	Set Reset Type (cold)
TF	Query or set receiver status and position fix information.
UT	Query or set UTC data
VR	Query and response to version information

NMEA 0183 message formats

GGA-GPS Fix Data

The GGA message includes time, position and fix related data for the GNSS receiver.

```
$GPGGA,hhmmss.sss,llll.lll,a,nnnnn.nnnnnn,b,t,uu, v.v,w.w,M,x.x,M,,*hh <CR><LF>
```

Field	Description
1	UTC of Position
2, 3	Latitude, N (North) or S (South)
4, 5	Longitude, E (East) or W (West)
6	GPS Quality Indicator: 0 = No GPS, 1 = GPS,
7	Number of Satellites in Use
8	Horizontal Dilution of Precision (HDOP)
9, 10	Antenna Altitude in Meters, M = Meters
11, 12	Geoidal Separation in Meters, M=Meters. Geoidal separation is the difference
13	Age of Differential GPS Data. Time in seconds since the last Type 1 or 9 update
14	Differential Reference Station ID (0000 to 1023)
hh	checksum

GLL - Geographic Position - Latitude/Longitude

The GLL message contains the latitude and longitude of the present vessel position, the time of the position fix and the status.

```
$GPGLL,llll.llllll,a,yyyyy.yyyyyy,b,hhmmss.sss,c,d*hh <CR> <LF>
```

Field	Description
1, 2	Latitude, N (North) or S (South)
3, 4	Longitude, E (East) or W (West)
5	UTC of Position
6	Status, A=Valid, V=Invalid
7	Mode Indicator: Mode A=Autonomous Mode D=Differential Mode E=Estimated (dead reckoning). Mode M=Manual Input Mode S=Simulated Mode N=Data Not Valid
hh	checksum

GSA - GPS DOP and Active Satellites

The GSA messages indicate the GNSS receiver's operating mode and lists the satellites used for navigation and the DOP values of the position solution.

`$idGSA,a,v,ww,ww,ww,ww,ww,ww,ww,ww,ww, , , ,x.xx,y.yy,z.zz*hh<CR><LF>`

Where 'id' is GP or GL, dependent on if the sentence contains GPS or GLONASS satellites.

Field	Description
1	Mode: M = Manual, A = Automatic. In manual mode, the receiver is forced to operate in
2	Current Mode: 1 = fix not available, 2 = 2D, 3 = 3D
3 - 14	PRN numbers of the satellites used in the position solution. When less than 12 satellites
15	Position dilution of precision (PDOP)
16	Horizontal dilution of precision (HDOP)
17	Vertical dilution of precision (VDOP)
hh	checksum

GSV - GPS Satellites in View

The GSV message identifies the GNSS satellites in view, including their PRN number, elevation, azimuth and SNR value. Each message contains data for four satellites. Second and third messages are sent when more than 4 satellites are in view. Fields #1 and #2 indicate the total number of messages being sent and the number of each message respectively.

`$idGSV,t,u,vv,ww,ww,www,ww,xx,xx,xxx,xx,yy,yy,yyy,yy,zz,zz,zzz,zz*hh<CR><LF>`

Where 'id' is GP or GL, dependent on if the sentence contains GPS or GLONASS satellites.

Field	Description
1	Total number of GSV messages
2	Message number: 1 to 3
3	Total number of satellites in view
4	Satellite PRN number
5	Satellite elevation in degrees (90° Maximum)
6	Satellite azimuth in degrees true (000 to 359)
7	Satellite SNR (C/No), null when not tracking
8, 9, 10, 11	PRN, elevation, azimuth and SNR for second satellite
12, 13, 14, 15	PRN, elevation, azimuth and SNR for third satellite
16, 17, 18, 19	PRN, elevation, azimuth and SNR for fourth satellite
hh	checksum

RMC - Recommended Minimum Specific GPS/Transit Data

The RMC message contains the time, date, position, course, and speed data provided by the GNSS navigation receiver. A checksum is mandatory for this message and the transmission interval may not exceed 2 seconds. All data fields must be provided unless the data is temporarily unavailable. Null fields may be used when data is temporarily unavailable.

```
$GPRMC,hhmmss.ss,a,llll.lllll,b,nnnnn.nnnnnn,c,x.xx,yyy,ddmmyy,,,d*hh<CR><LF>
```

Field	Description
1	UTC of Position Fix.
2	Status: A – Valid, V - Navigation receiver warning
3, 4	Latitude, N (North) or S (South).
5, 6	Longitude, E (East) or W (West).
7	Speed over the ground (SOG) in knots
8	Track made good in degrees true.
9	Date: dd/mm/yy
10, 11	Magnetic variation in degrees, E = East / W= West
12	Position System Mode Indicator A - Autonomous D - Differential E - Estimated (Dead Reckoning) M - Manual Input S - Simulation Mode N - Data Not Valid
hh	Checksum (Mandatory for RMC)

VTG - Track Made Good and Ground Speed

The VTG message conveys the actual track made good (COG) and the speed relative to the ground (SOG).

```
$GPVTG,xxx,T,,M,y.yyy,N,z.zzz,K,a*hh<CR><LF>
```

Field	Description
1,2	Track made good in degrees true.
3,4	Track made good in degrees magnetic.
5,6	Speed over the ground (SOG) in knots
7,8	Speed over the ground (SOG) in kilometer per hour
9	Position System Mode Indicator A - Autonomous

Field	Description
	D - Differential
	E - Estimated (Dead Reckoning)
	M - Manual Input
	S - Simulation Mode
	N - Data Not Valid
hh	Checksum

ZDA - Time & Date

The ZDA message contains UTC time, the day, the month, the year and the local time zone.

```
$GPZDA,hhmmss.sss,dd,mm,yyyy,,*hh<CR><LF>
```

Field	Description
1	UTC
2	Day (01 to 31)
3	Month (01 to 12)
4	Year
5	Unused
hh	Checksum

Note – Fields #5 and #6 are null fields in the ICM/RES SMT 360™ output. A GNSS receiver cannot independently identify the local time zone offsets.

CAUTION – If UTC offset is not available, time output will be in GPS time until the UTC offset value is collected from the GPS satellites. When the offset becomes available, the time will jump to UTC time.

Note – GPS time can be used as a timetag for the 1PPS. The ZDA message comes out 100–500 msec after the PPS.

AH - Almanac Health

Use this message to query or set almanac health data. Since the maximum number of bytes that can be contained in a single NMEA sentence is less than the total almanac health length, the almanac health must be sent in two parts that have to be sent or received together in the correct sequence. After receiving the query, the receiver sends out two messages.

Message 1

\$PTNL_aAH,1,hh,hhhhhhhh,hhhhhhhh,hhhhhhhh,hh*hh<CR><LF>

Field	Description
a	Mode Q – Query S – Set R – Response
hh	Week number for health, variable length integer, 4 digits maximum
hhhhhhhh	Satellite 1 - 4 health, one byte for each satellite, HEX data conforming to GPS ICD 200.
hhhhhhhh	Satellite 5 - 8 health, one byte for each satellite, HEX data conforming to GPS ICD 200.
hhhhhhhh	Satellite 9 - 12 health, one byte for each satellite, HEX data conforming to GPS ICD 200.
hhhhhhhh	Satellite 13 - 16 health, one byte for each satellite, HEX data conforming to GPS ICD 200
hh	Checksum

Message 2

\$PTNL_aAH,2,hh,hhhhhhhh,hhhhhhhh,hhhhhhhh,hh*hh<CR><LF>

Field	Description
a	Mode Q – Query S – Set R – Response
hh	Week number for health, variable length integer, 4 digits maximum
hhhhhhhh	Satellite 17 - 20 health, one byte for each satellite, HEX data conforming to GPS ICD 200.
hhhhhhhh	Satellite 21 - 24 health, one byte for each satellite, HEX data conforming to GPS ICD 200.
hhhhhhhh	Satellite 25 - 28 health, one byte for each satellite, HEX data conforming to GPS ICD 200.
hhhhhhhh	Satellite 29 - 32 health, one byte for each satellite, HEX data conforming to GPS ICD 200
hh	Checksum

AL - Almanac Page

Use this sentence to query or set almanac data for a specific satellite. The query format is:

\$PTNLQAL,xx*hh<CR><LF>

Field	Description
xx	Satellite ID

The set or response format is as follows:

\$PTNLAL,xx,x.x,hh,hhhh,hh,hhhh,hhhh,hhhhhh,hhhhhh,hhhhhh h,hhhhhh,hhh,hhh*
 hh<CR><LF>

Field	Description
a	Mode S – Set R – Response
xx	Satellite ID, 01-32.
x.x	GPS week number, variable length integer, 4 digits maximum.
hh	SV health, HEX data conforming to GPS ICD 200
hhhh	Eccentricity, HEX data conforming to GPS ICD 200.
hh	t_oa, almanac reference time, HEX data conforming to GPS ICD 200.
hhhh	sigma_l, HEX data conforming to GPS ICD 200
hhhh	OMEGADOT, HEX data conforming to GPS ICD 200.
hhhhhh	root_a, HEX data conforming to GPS ICD 200.
hhhhhh	Omega, HEX data conforming to GPS ICD 200.
hhhhhh	Omega_0, HEX data conforming to GPS ICD 200.
hhhhhh	M_O, HEX data conforming to GPS ICD 200.
hhh	a_fO, HEX data conforming to GPS ICD 200.
hhh	a_fl, HEX data conforming to GPS ICD 200.
hh	checksum

AS - Almanac Status

Use this sentence to query or set almanac status. The query format is:

\$PTNLAS,hh,xxxx,hh,hh,hh,hh,hh*hh<CR><LF>

Field	Description
a	Mode Q – Query S – Set R – Response
hh	Time of almanac
xxxx	Week of number of almanac
hh	Reserved
hh	Reserved
hh	Reserved
hh	Reserved

Field	Description
hh	Almanac Status 0 – almanac incomplete 1 – almanac complete and current
hh	Checksum

The corresponding response for the set is:

```
$PTNLRAS,a*hh<CR><LF>
```

Where “a” is the action status: A = success; V= failure.

BA - Antenna Status

Use this sentence to query the antenna connection status. Only issue it when the antenna detection circuit is implemented. The query format is:

```
$PTNLQBA*hh<CR><LF>
```

The Response to query sentence format is:

```
$PTNLRBA,a,b*hh<CR><LF>
```

Field	Description
a	Status (0 = status unavailable, 1 = status available)
b	Antenna feedline fault: 0 = normal 1 = open 2 = short
hh	Checksum

CR - Configure Receiver

Use this sentence to query or set NMEA receiver configuration information.

```
$PTNLaCR,x.x,x.x,x.x,x.x,x.x,a,a*hh<CR><LF>
```

Field	Description
a	Mode Q – Query S – Set R – Response
x.x	Signal level mask in dB-Hz (default = 0 dB-Hz). The signal level mask is used only when the receiver is operating in the Over Determined Clock mode
x.x	Elevation mask in degrees (default = 10 degrees). The elevation mask is used only when the receiver is operating in the Over Determined Clock mode.

Field	Description
x.x	Reserved
x.x	Reserved
x.x	Reserved
A	Receiver Mode 0 – automatic 7 – over-determined clock
a	Reserved
A	Reserved
hh	Checksum

EM - Enter Monitor Mode

This sentence is used to set the ICM/RES SMT 360™ multi-GNSS timing module into Monitor mode. This is Set only, no query supported. The sentence format is:

```
$PTNLSEM*hh<CR><LF>
```

This sentence is used by the Firmware Uploading Program.

EP - Ephemeris

Use this sentence to query or set ephemeris data for a specific satellite. Since the maximum number of bytes that can be contained in a single NMEA sentence is less than the total ephemeris data length, the ephemeris data must be sent in three sentences. The three sentences have to be sent or received together in correct sequence. The query format is:

```
$PTNLQEP,xx*hh<CR><LF>
```

Field	Description
Q	Query
xx	Satellite ID
hh	Checksum

After receiving the query, the receiver should send out three messages.

Message 1

```
$PTNLaEP,1,xx,x.x,x.x,hh,hh,hh,hh,hhh,hh,hhhh,hh,hhhh,hh hhhh,x .x*hh<CR><LF>
```

Field	Description
a	Mode S – Set R – Response

Field	Description
1	Message number for EP, message 1 must be sent or received before message 2, and message 2 must be sent or received before message 3, and all three messages must be sent together with correct sequence
xx	Satellite id
x.x	T_ephem, This is a double precision floating point number.
x.x	Week number for health, variable length integer, 4 digits maximum.
hh	CodeL2, HEX data conforming to GPS ICD 200.
hh	L2Pdata, HEX data conforming to GPS ICD 200.
hh	Svacc_raw, HEX data conforming to GPS ICD 200.
hh	SV_health, HEX data conforming to GPS ICD 200.
hhh	IODC, HEX data conforming to GPS ICD 200.
hh	T_GD, HEX data conforming to GPS ICD 200.
hhhh	T_oc, HEX data conforming to GPS ICD 200.
hh	A_f2, HEX data conforming to GPS ICD 200.
hhhh	A_f1, HEX data conforming to GPS ICD 200.
hhhhhh	A_f0, HEX data conforming to GPS ICD 200
hh	Checksum

Message 2

\$PTNLaEP,2,xx,hh,hh,hhhh,hhhh,hhhhhhhh,hhhh,hhhhhhhh,hhh h,hhhhhhhh,hhhh*
hh<CR><LF>

Field	Description
a	Mode S – Set R – Response
2	Sentence number for EP, sentence 1 must be sent or received before sentence 2, and sentence 2 must be sent or received before sentence 3, and all three sentences must be sent together
xx	Satellite id
hh	IODE, Hex data conforming to GPS ICD 200
hh	Fit_interval, Hex data conforming to GPS ICD 200
hhhh	C_rs, Hex data conforming to GPS ICD 200
hhhh	Delta_n, Hex data conforming to GPS ICD 200
hhhhhhh	M_0, Hex data conforming to GPS ICD 200
hhhh	C_uc, Hex data conforming to GPS ICD 200
hhhhhhh	E, Hex data conforming to GPS ICD 200
hhhh	C_us, Hex data conforming to GPS ICD 200

Message 3

\$PTNLaEP,3,xx,hhhh,hhhhhhhh,hhhh,hhhhhhhh,hhhh,hhhhhhhh, hhhhhh,hhhh*hh< CR><LF>

Field	Description
a	Mode S – Set R – Response
3	Sentence number for EP, sentence 1 must be sent or received before sentence 2, and sentence 2 must be sent or received before sentence 3, and all three sentences must be sent together
xx	Satellite id
hh	C_ic, Hex data conforming to GPS ICD 200
hh	OMEGA_0, Hex data conforming to GPS ICD 200
hhhh	C_ri, Hex data conforming to GPS ICD 200
hhhh	I_O, Hex data conforming to GPS ICD 200
hhhhhhh	C_rc, Hex data conforming to GPS ICD 200
hhhh	OMEGA, Hex data conforming to GPS ICD 200
hhhhhhh	OMEGA_DOT, Hex data conforming to GPS ICD 200
hhhh	IDOT, Hex data conforming to GPS ICD 200
hh	Checksum

IO - Ionosphere

This sentence can be used to query or set ionosphere data.

\$PTNLaIO,hh,hh,hh,hh,hh,hh,hh,hh*hh,<CR><LF>

Field	Description
a	Mode Q – Query S – Set R – Response
hh	Alpha_0, HEX data conforming to GPS ICD 200.
hh	Alpha_1, HEX data conforming to GPS ICD 200.
hh	Alpha_2, HEX data conforming to GPS ICD 200.
hh	Alpha_3, HEX data conforming to GPS ICD 200.
hh	Beta_0, HEX data conforming to GPS ICD 200.
hh	Beta_1, HEX data conforming to GPS ICD 200.
hh	Beta_2, HEX data conforming to GPS ICD 200.
hh	Beta_3, HEX data conforming to GPS ICD 200
hh	Checksum

KG - Set Initial Position

Use this sentence to set initial position or time info data or both for accelerating navigation startup:

- To set time only, send valid time fields and NULL position fields.
- To set position only, send valid position fields and NULL time fields. Query is not supported.

```
$PTNLaKG,x.x,x.x,IIII.IIIII,a,yyyyy.yyyyy,a,x.x*hh<CR><LF>
```

Note – When uploading a position, it should be within 100 Km of the actual position and time within 5 minutes of UTC.

Field	Description
a	Mode S – Set R – Response
x.x	GPS week number, maximum 4 digits
x.x	GPS time of week in milliseconds
IIII.IIIII	Latitude
a	N S
yyyyy.yyyyy	Longitude
a	E W
x.x	Altitude from the sea level in meters (maximum 5 digits)
hh	Checksum

NM - Automatic Message Output

This sentence may be issued by the user to configure automatic message output. The Query sentence format is:

```
$PTNLQNM*hh<CR><LF>
```

The Response to query sentence or Set sentence format is:

```
$PTNLaNM,hhhh,xx*hh<CR><LF>
```

Field	Description
a	Mode Q - Query S – Set

Field	Description
	R – Response
hhhh	Bit 0 -GGA Bit 1 -GLL Bit 2 -VTG Bit 3 -GSV Bit 4 -GSA Bit 5 -ZDA Bit 8 -RMC Bit 9 -TF Bit 10 -GST Bit 13 -BA
xx	Automatic Report Interval (1 – 99)
hh	Checksum

Examples

GGA Only	0001
GLL Only	0002
VTG Only	0004
GSV Only	0008
GSA Only	0010
ZDA Only	0020
RMC Only	0100
TF Only	0200
GST Only	0400
BA Only	2000
GGA and GLL	0003
GGA and TF	0201
RMC and TF	0300
GGA, GLL and TF	0203

PS - PPS Configuration

This sentence can query or set PPS configuration data.

\$PTNLaPS,b,x...x,c,x...x*hh<CR><LF>

Field	Description
a	Mode Q – Query S – Set R – Response
b	PPS mode, default is 1 0 – PPS_OFF (Always Off)

Field	Description
	1 – PPS_ON (Always On or Early PPS)
	2 – Reserved
	3 – Reserved
x...x	Reserved
c	Output pulse polarity, default is 1: 0 -output pulse is active low 1 -output pulse is active high
x...x	Antenna Cable Length Compensation. Default = 0, Units in nanoseconds. Can be positive or negative. Negative value will mean PPS comes out earlier, e.g. to compensate for cable delay Field value range is -100000000...100000000 (±100 milliseconds)
hh	Checksum

PT - Serial Port Configuration

This sentence may be issued by the user for configuring the current serial port. The Query sentence format is:

```
$PTNLQPT*hh<CR><LF>
```

The Response to query or Set sentence format is:

```
$PTNLRPT,xxxxxx,b,b,b,h,h*hh<CR><LF>
```

When the Set is issued, the first Response sentence is sent using the old parameters and the second response sentence is sent using the new parameters. If there is an error, an error response is sent. If there is no error, no additional response is sent.

Field	Description
a	Mode Q - Query S – Set R – Response
xxxxxx	Baud rate (4800, 9600, 19200, 38400, 57600, 115200). Default baud rate is 4800
b	# of data bits (7 or 8)
b	Parity (N - none, O - odd, E - even)
b	# of stop bits (1 or 2)
h	Input protocol, hex value (bit 0: reserved, bit1: TSIP, bit2: NMEA, bit 3: Reserved). Bits
h	Output protocol, hex value (bit 0: reserved, bit1: TSIP, bit2: NMEA, bit 3: reserved). It is not recommended to combine multiple output protocols
hh	Checksum

RT - Reset

This sentence can be used to Set the reset type. No query is supported.

```
$PTNLART,b,c*hh<CR><LF>
```

Field	Description
a	Mode S – Set R – Response
b	Command C = Cold software reset, Erases RAM including the customer configuration in RAM and restarts F = Factory software reset. Erases the customer configuration, the almanac, ephemeris and last position in Flash Memory and in SRAM
c (decimal integer)	Flash operation 0 - Do not do any Flash operation 1 - reserved 2 - store user configuration to Flash Memory 3 - reserved 4 - reserved 5 - Erase user configuration from Flash Memory 6 – reserved
hh	Checksum

Note – A successful command is followed by a \$PTNLRRT,A*3F response. An incorrect command will be followed by a \$PTNLRRT,V*28 response.

Note – To save user configuration to flash memory, send command \$PTNLSRT,C,2*22.

TF - Receiver Status and Position Fix

This sentence may be issued by the user to get receiver status and position fix. The Query sentence format is:

```
$PTNLQTF*hh<CR><LF>
```

The Response to query sentence format is:

```
$PTNLATF,b,c,xxxxxx,xx,x,IIII.IIIII,d,yyyyy.yyyyy,e,xxxx x,x.x,x.x,x.x*hh<CR><LF>
```

Field	Description
a	Mode Q - Query R – Response
b	BGRAM status on startup (A = valid; V = invalid)
c	Almanac completion status (A = complete; V = incomplete)
xxxxxx	GPS time of week (in seconds)
xx	Number of satellites in use, 00 - 12, may be different from the number in view.
x	Position fix source (0 = no fix; 1 = Stationary Mode, 2 = 2D fix; 3 = 3D fix)
llll.llll	Latitude of the current position fix
yyyyy.yyyyy	Longitude of the current position fix
e	E W
xxxxx	Antenna altitude re: mean-sea-level (MSL geoid, meters)
x.x	'East' component of ENU velocity (m/s)
x.x	'North' component of ENU velocity (m/s)
x.x	'Up' component of ENU velocity (m/s)
hh	Checksum

UT - UTC

Use this sentence to query or set UTC data.

```
$PTNLaUT,hhhhhhhh,hhhhhh,hh,hh,hhhh,hhhh,hh,hh*hh<CR><LF>
```

Field	Description
a	Mode Q - Query S – Set R – Response
hhhhhhhh	A_0, HEX data conforming to GPS ICD 200.
hhhhhh	A_1, HEX data conforming to GPS ICD 200.
hh	Delta_t_ls, HEX data conforming to GPS ICD 200.
hh	T_oa, HEX data conforming to GPS ICD 200.
hhhh	Wn_t, HEX data conforming to GPS ICD 200.
hhhh	Wn_LSF, HEX data conforming to GPS ICD 200.
hh	DN, HEX data conforming to GPS ICD 200.

hh Delta_t_LSF, HEX data conforming to GPS ICD 200
hh Checksum

VR - Version

This sentence may be issued by the user to get application version information. The Query sentence format is:

\$PTNLQVR,a*hh<CR><LF>

where a is S = Application firmware, H=Hardware information

The Response to query sentence format is:

\$PTNLRaVR,b,c..c,xx.xx.xx,xx,xx,xxxx*hh<CR><LF>

Application firmware

Field	Description
a	Mode Q – Query R – Response
b	Application firmware (S)
c..c	Receiver Name
xx	Major version
xx	Minor version
xx	Build version
xx	Month
xx	Day
xxxx	Year
hh	Checksum

Hardware version

Field	Description
a	Mode Q - Query R – Response
b	Hardware information indicator (H)
xxxx	Hardware ID
xxxxxxx	Serial number
xx	Build month

Field	Description
xx	Build day
xxxx	Build year
xx	Build hour
hh	Checksum

ZD – Extended Time and Date

This message reports extended time and date information - UTC, day, month, year, local time zone and UTC to GPS leap second.

Setting the data is not supported.

This message is output automatically if selected in the NMEA message output mask.

Query format:

```
$PTNLQZD*hh<CR><LF>
```

Response to query format:

```
$PTNLRZD, hhmmss.s,dd,mm,yyyy,zh,zm,ls,lsp*hh<CR><LF>
```

Field	Description
hhmmss.s	Hours, minutes, seconds, sub-seconds of position in UTC.
dd	Day (01 to 31)
mm	Month (01 to 12)
yyyy	Year
zh	Local Zone Hour, offset from UTC to obtain Local time
zm	Local Zone Minute
ls	Current leap second offset between GPS and UTC time
lsp	Pending leap second. If non-zero (+/- 1) then a leap second is scheduled to occur at the end of the day. The sign indicates the direction of the leap second.
hh	Checksum

Exception behavior

When no position fix is available, some of the data fields in the NMEA messages will be blank. A blank field has no characters between the commas.

Interruption of GNSS signal

If the GNSS signal is interrupted temporarily, the NMEA will continue to be output according to the user-specified message list and output rate. Position and velocity fields will be blank until the next fix, but most other fields will be filled.



Contact Information

NORTH AMERICA

Trimble, Inc.
Corporate Headquarters
935 Stewart Drive
Sunnyvale, CA 94085
+1-800-787-4225
+1-408-481-7741

EUROPE

Trimble Navigation Europe
Phone: +46-8-622-12-79

KOREA

Trimble Export Ltd, Korea
Phone: +82-2-555-5361

CHINA

Trimble Navigation Ltd, China
Phone: +86-10-8857-7575

TM

**The right one.**TM

www.trimble.com/timing

**Trimble**[®]